

TM 11-400A

DEPARTMENT OF THE ARMY TECHNICAL MANUAL

PHOTOGRAPHIC SET

ES-12 (1)

This copy is a reprint which includes current pages from Changes 1 thru 3.

CHANGE }
No. 3 }

HEADQUARTERS
DEPARTMENT OF THE ARMY
WASHINGTON, D. C., 8 October 1973

PHOTOGRAPHIC SET ES-12 (1)

TM 11-400A, 6 January 1955, is changed as follows:

Page 3. Paragraph 2 is superseded as follows:

2. Indexes of Publications

a. DA Pam 310-4. Refer to the latest issue of DA Pam 310-4 to determine whether there are new editions, changes or additional publications pertaining to the equipment.

b. DA Pam 310-7. Refer to DA Pam 310-7 to determine whether there are modification work orders (MWO's) pertaining to the equipment.

2.2. Forms and Records

a. Reports of Maintenance and Unsatisfactory Equipment. Maintenance forms, records, and reports which are to be used by maintenance personnel at all maintenance levels are listed in and prescribed by TM 38-750.

b. Report of Packaging and Handling Deficiencies. Fill out and forward DD Form 6 (Report of Packaging and Handling Deficiencies) as prescribed in AR 700-58 (Army)/NAVSUP Pub 378 (Navy)/AFR 71-4 (Air Force) /and MCO P4030.29 (Marine Corps).

c. Discrepancy in Shipment Report (DISREP) (SF 361). Fill out and forward Discrepancy in Shipment Report (DISREP) (SF 361) as prescribed in AR 55-38 (Army)/NAVSUP Pub 459 (Navy)/AFM 75-34 (Air Force) /and MCO P4610.19 (Marine corps) .

Paragraph 3*b.* Change title of subparagraph *b* to "Table of Components and Dimensions."

After subparagraph *b* add:

c. Items Comprising an Operable Photographic Set ES-12(1).

FSN	QTY	Nomenclature, part No., and mfr code	Usable on code
		NOTE The part number is followed by the applicable 5-digit Federal supply code for manufacturers (FSCM) identified in SB 708-42 and used to identify manufacturer, distributor, or Government Agency, etc.	
6135-120-1010		Battery BA-42 (Not installed)	
		NOTE Dry batteries shown are used with the equipment but are not considered part of the equipment. They will not be preshipped automatically but are to be requisitioned in quantities necessary for the particular organization in accordance with SB 11-6.	
6760-408-5005	1	Board PH-317H (Not installed)	
6760-498-9952	1	Cable Release PH-308 (Not installed)	
6760-515-0342	1	Camera, Still Picture KE-7 (1) (Not installed)	
6780-408-5390	1	Clamp: "Kodapod" U-10269; 19671 (Not installed)	
6740-224-9586	6	Clip PH-165 (Not installed)	
8305-281-2884	1	Cloth, Textile: CCC-C271, type #11; 81348 (Not installed)	
6760-356-5481	1	Filter, Light: 5023; 82123 (Not installed)	
6760-570-9225	1	Flash, Gun Photographic: Kalert Model No. BC-421 (Not installed)	
6640-762-7678	1	Graduate PH-11 (Not installed)	
6760-523-6090	1	Lens, Supplementary: Proxar 5032; 83123 (Not installed)	
6760-597-1427	1	Lens, Supplementary: Proxar 5031 (Not installed)	
6760-810-8385	1	Meter, Photographic LM-46A (Not installed)	
6740-292-9675	1	Printer, Projection Photographic EN-11 (1) and EN-11 (2) (Installed in equip)	

FSN	QTY	Nomenclature, part No., and mfr code	Unable on code
6720-533-6353	1	Ring, Adapter: 5044; 82123 (Not installed)	
6760-318-6802	1	Ring, Retaining: 5016; 82123 (Not installed)	
6740-550-2112	2	Rod, Stirring: RX10618; 81349 (Not installed)	
7510-161-6215	1	Rule	
6740-224-9565	1	Tank PH-322 (Not installed)	
6760-521-0656	1	Thermometer PH-28 (Not installed)	
6645-243-9470	1	Timer FM-103 (1) (Not installed)	
6740-243-2941	3	Tray PH-158-A (Not installed)	
		PRINTER PROJECTION, PHOTOGRAPHIC EN-11(1); EN-11(2)	
		NOTE In usable on code column, number refers to EN-11(1); number 2 refers to EN-11(2)	
6740-318-6797	1	Carrier, Negative: EN-21; 94225 (Not installed)	1.2
6760-201-1302	1	Filter, Light: EN-29; 90383 (Installed in equip)	1
6760-958-7406	1	Filter, Light: EN-29; 94225 (Not installed)	2
6760-959-1519	1	Holder, Filter: TN-27; 94225 (Not installed)	2
6760-397-3540	1	Lens, Projection: Wollensak Rapter Enlarger Lens (Installed in equip)	1
6760-958-7397	1	Lens, Projection Printing: Elgeet Optical CO. p/n E5145 (Installed in equip)	2

d. Expendable Consumable Items. A list of expendable consumable items required for operation appears in table 1-1.

Table 1-1. Expendable Consumable Supplies and Materials

The supplies and material listed in this table are required for operation of this equipment and are authorized to be requisitioned by SB 700-50. The FSN for the applicable unit of issue required can be found in appropriate supply catalogs. The FSCM is used as an element in item identification to designate manufacturer or distributor or Government Agency, etc, and is identified in SB 708-42.

Item	Description	Ref No. and FSCM	FSC
1	Filter, Light: (Installed in equip)	EN-29, 90383	6760
2	Paper, Lens: (Not installed)	UU-P-313, 81348	6640
3	Sponge, Cellulose: (Not installed)	L-S-626, type 11, 81348	7920

Page 78. Appendix III is superseded as follows:

APPENDIX III

BASIC ISSUE ITEMS LIST (BIIL) AND ITEMS TROOP INSTALLED OR AUTHORIZED LIST (ITIAL)

Section I. INTRODUCTION

1. Scope

This appendix lists only basic issue items required by the crew/operator for installation, operation, and maintenance of Photographic Set ES-12(1).

2. General

This Basic Issue Items and Items Troop Installed or Authorized List is divided into the following section:

a. Basic Issue Items List-Section II. A list, in alphabetical sequence, of items which are furnished with, and which must be turned in with the end item.

b. Items Troop Installed or Authorized List-Section III. Not applicable.

3. Explanation of Columns

The following provides an explanation of columns found in the tabular listing:

a. Illustration. Not applicable.

b. Federal Stock Number. Indicates the Federal stock number assigned to the item and will be used for requisitioning purposes.

c. Part Number. Indicates the primary number used by the manufacturer (individual, company, firm, corporation, or government activity), which controls the design and characteristics of the item by means of its engineering drawings, specifications standards, and inspection requirements, to identify an item or range of items.

d. *Federal Supply Code for Manufacturer (FSCM)*. The FSCM is a 5-digit numeric code used to identify the manufacturer, distributor, or Government agency, etc., and is identified in SB 708-42.

e. *Description*. Indicates the Federal item name and a minimum description required to identify the item.

f. *Unit of Measure (U/M)*. Indicates the standard of basic quantity of the listed item as used in performing the actual maintenance function. This measure is expressed by a two-character alphabetical abbreviation, (e.g., ea, in., pr, etc). When the unit of measure differs from the unit of issue, the lowest unit of issue that will satisfy the required units of measure will be requisitioned.

g. *Quantity Furnished with Equipment (Basic Issue Items Only)*. Indicates the quantity of the basic issue item furnished with the equipment.

h. *Quantity Authorized (Items Troop Installed or Authorized Only)*. Not applicable.

4. Special Information

Usable on codes are included in description column. Uncoded items are applicable to all models. Identification of the usable on codes are as follows:

<i>Code</i>	<i>Used on</i>
1	ES-12(1)
2	EN-11(2)

Section II. BASIC ISSUE ITEMS LIST

(1) Illustration		(2) Federal stock number	(3) Part number	(4) FSCM	(5) Description Usable on code	(6) Unit of meas	(7) Qty furn with equip
(A) Fig. No.	(B) Item No.						
		6760-664-4013	2313		CAP LENS, ELGEET 2 OPTICAL CO (INSTALLED IN EQUIP)	EA	1
		6760-286-7881			CARRYING CASE, PHOTO-1 GRAPHIC EQUIPMENT FM 22(1) (NOT IN- STALLED)	EA	1

By Order of the Secretary of the Army:

CREIGHTON W. ABRAMS
General, United States Army
Chief of Staff

Official:

VERNE L. BOWERS
Major General, United States Army
The Adjutant General

Distribution:

Active Army:

USASA (2)	Ft Richardson (ECOM Ofc) (2)
CNGB (1)	WSMR (1)
ACSC-E (2)	Army Dep (2) except
Dir of Trans (1)	LBAD (14)
COE (1)	SAAD (30)
TSG (1)	TOAD (14)
USAARENBD (1)	ATAD (10)
USAMB (10)	USA Dep (2)
AMC (1)	Sig Sec USA Dep (5)
FORSCOM (5)	Sig Dep (5)
ARADCOM (2)	Sig FLDMS (2)
ARADCOM Rgn (2)	USAERDAA (1)
OS Maj Comd (4)	USAERDAW (1)
LOGCOMDS (3)	MAAG (1)
MICOM (2)	USARMIS (1)
TECOM (2)	Units org under fol TOE:
USASTRATCOM (4)	(1 cy each unit)
MDW (1)	5-35
Armies (2)	5-36
Corps (2)	5-97
HISA (ECOM) (21)	11-16
Svc Colleges (1)	11-96
USASESS (5)	11-117
USAADS (2)	11-158
USAFAS (2)	11-500 (AA-AC)
USAARMS (2)	19-35
USAIS (2)	19-36
USAES (2)	19-217
USAINTS (3)	29-500
WRAMC (1)	29-56
USACDCEC (10)	29-134
ATS (1)	29-136
USAMPS (2)	30-17
AV Comm Cen (1)	30-18
Instl (2) except	30-25
Fort Gordon (10)	30-26
Fort Huachuca (10)	30-500
Fort Carson (10)	39-51

39-52
54-422

54-502
57

NG: State AG (3)

USAR: None

For explanation of abbreviations used, see AR 310-50.

PHOTOGRAPHIC SET ES-12(1)

CHANGE }
No. 2 }

HEADQUARTERS
DEPARTMENT OF THE ARMY
WASHINGTON, D.C., 14 December 1964

TM 11-400A, 6 January 1955, is changed as follows:

Note. The parenthetical reference to a previous change (example: "page 1 of C 1") indicates that pertinent material was published in that change.

Page 52, chapter 4 (page 7 of C 1). Redesignate paragraph "24.2. Tools, Materials, and Test Equipment required," as: 24.2 1.

Page 78, appendix (page 9 of C 1). Change "Appendix" to: Appendix I.

(Page 10 of C 1) Add the following to the references:

- TM 11-6720-205-10P Operator Maintenance Repair Parts and Special Tools List; Camera, Still Picture KE-7(1).
- TM 11-6720-205-20P Organizational Maintenance Repair Parts and Special Tools List and Maintenance Allocation Chart; Camera, Still Picture KE-7(1).
- SIG 7&8 FM 22(1) Carrying Case, Photographic Equipment FM-22(1) (including case PH-318).

Add appendix II after appendix I.

APPENDIX II

MAINTENANCE ALLOCATION

Section I. INTRODUCTION

1. General

a. This appendix assigns maintenance functions to be performed on components, assemblies, and subassemblies by the lowest appropriate maintenance category.

*This change supersedes so much of Department of The Army Supply Manual SIG 7 & 8, ES-12 (1), 6 November 1957, and EN-11 (1), 6 November 1957, as pertains to first echelon items.

- b. Columns in the maintenance allocation chart are as follows:
- (1) *Part or component.* This column shows only the nomenclature or standard item name. Additional descriptive data are included only where clarification is necessary to identify the component. Components, assemblies, and subassemblies are listed in top-down order. That is, the assemblies which are part of a component are listed immediately below that component, and the subassemblies which are part of an assembly are listed immediately below that assembly. Each generation breakdown (components, assemblies, or subassemblies) is listed in disassembly order or alphabetical order.
 - (2) *Maintenance function.* This column indicates the various maintenance functions allocated to the categories.
 - (a) *Service.* To clean, to preserve, and to replenish lubricants.
 - (b) *Adjust.* To regulate periodically to prevent malfunction.
 - (c) *Inspect.* To verify serviceability and to detect incipient electrical or mechanical failure by scrutiny.
 - (d) *Test.* To verify serviceability and to detect incipient electrical or mechanical failure by use of special equipment such as gages, meters, and other test devices.
 - (e) *Replace.* To substitute serviceable components, assemblies, or subassemblies, for unserviceable components, assemblies, or subassemblies.
 - (f) *Repair.* To restore an item to serviceable condition through correction of a specific failure or unserviceable condition. This function includes but is not limited to welding, grinding, riveting, straightening, and replacement of parts other than the trial and error replacement of running spare type items such as fuses, lamps, or electron tubes.
 - (g) *Align.* To adjust two or more components of an electrical system so that their functions are properly synchronized.
 - (h) *Calibrate.* To determine, check, or rectify the graduation of an instrument, weapon, or weapons system, or components of a weapons system.
 - (i) *Overhaul.* To restore an item to *completely serviceable* condition as prescribed by serviceability stand-

ards developed and published by heads of technical services. This is accomplished through employment of the technique of "Inspect and Repair Only as Necessary" (IROAN). Maximum utilization of diagnostic and test equipment is combined with minimum disassembly of the item during the overhaul process.

- (j) *Rebuild.* To restore an item to a standard as near as possible to original or new condition in appearance, performance, and life expectancy. This is accomplished through the maintenance technique of complete disassembly of the item, inspection of all parts or components, repair or replacement of worn or un-serviceable elements using original manufacturing tolerances and/or specifications and subsequent reassembly of the item.
- (3) *Operator, organizational, direct support, general support, and depot maintenance levels categories.* The symbol X indicates the category responsible for performing that particular maintenance operation, but does not necessarily indicate that repair parts will be stocked at that level. Categories higher than those marked by X are authorized to perform the indicated operation.
- (4) *Tools required.* This column indicates codes assigned to each individual tool equipment, test equipment, and maintenance equipment referenced. The grouping of codes in this column of the maintenance allocation chart indicates the tool, test, and maintenance equipment required to perform the maintenance function.
- (5) *Remarks.* Entries in this column will be utilized when necessary to clarify any of the data cited in the preceding column.

c. Columns in the allocation of tools for maintenance functions are as follows:

- (1) *Tools required for maintenance functions.* This column lists tools, test, and maintenance equipment required to perform the maintenance functions.
- (2) *Operator, organizational, direct support, general support, and depot maintenance levels.* The dagger (†) indicates the categories normally allocated the facility.
- (3) *Tool code.* This column lists the tool code assigned.

2. Maintenance by Using Organizations

When this equipment is used by signal services organizations organic to theater headquarters or communication zones to provide theater communications, those maintenance functions allocated up to and including general support are authorized to the organization operating this equipment.

Section II. MAINTENANCE ALLOCATION CHART

Part or component	Maintenance function	Category					Tools required	Remarks
		1	2	3	4	5		
PHOTOGRAPHIC SET ES-12(1) CAMERA STILL PICTURE KE-7(1) PRINTER, PROJECTION, PHOTOGRAPHIC EN-11(1); EN-11(2).	service	X					1 2 2, 3 1 2, 3 2, 3	See TM 11-6720-205-20.
	inspect	X						
	test		X					
	repair		X					
	overhaul				X			
	repair							
	service	X						
	inspect	X						
	test		X					
	repair		X					
	rebuild					X		
	overhaul				X			

Section III. ALLOCATION OF TOOLS FOR MAINTENANCE FUNCTIONS

Tools required for maintenance functions	Category					Tool code	Remarks
	1	2	3	4	5		
ES-12(1) (continued)							
MULTIMETER AN/URM-105		†				1	
TOOL KIT, PHOTOGRAPHIC REPAIR TK-77/GF		†				2	
TOOL KIT, PHOTOGRAPHIC REPAIR TK-109/GF			†	†	†	3	

Add appendix III after appendix II.

APPENDIX III

BASIC ISSUE ITEMS LIST

Section I. INTRODUCTION

1. Scope

a. This appendix lists items supplied for initial operation and for running spares. The list includes tools, parts, and material issued as part of the major end item. The list includes all items authorized for basic operator maintenance of the equipment. End items of equipment are issued on the basis of allowances prescribed in equipment authorization tables and other documents that are a basis for requisitioning.

b. Columns are as follows:

- (1) *Federal stock number.* This column lists the 11-digit Federal stock number.
- (2) *Designation by model.* The dagger (†) indicates model in which the part is used.
- (3) *Description.* Nomenclature or the standard item name and brief identifying data for each item are listed in this column. When requisitioning, enter the nomenclature and description.
- (4) *Unit of issue.* The unit of issue is each unless otherwise indicated and is the supply term by which the individual item is counted for procurement, storage, requisitioning, allowances, and issue purposes.
- (5) *Expendability.* Nonexpendable items are indicated by NX. Expendable items are not annotated.
- (6) *Quantity authorized.* Under "Items Comprising an Operable Equipment," the column lists the quantity of items supplied for the initial operation of the equipment. Under "Running Spare Items," the quantities listed are those issued initially with the equipment as spare parts. The quantities are authorized to be kept on hand by the operator for maintenance of the equipment.

2. Batteries

Dry batteries shown are used with the equipment but are not considered part of the equipment. They will not be preshipped automatically but are to be requisitioned in quantities necessary for the particular organization, in accordance with SB 11-6.

Section II. FUNCTIONAL PARTS LIST

Federal stock number	Designation by model					Description	Unit of issue	Exp	Qty auth	Illustration	
										Fig. No.	Item No.
6780-498-9921						PHOTOGRAPHIC SET ES-12(1): portable 35 mm photographic field unit for taking, processing, and enlarging still picture.		NX			
ORD THRU AGC						ITEMS COMPRISING AN OPERABLE EQUIPMENT					
6135-120-1010						TECHNICAL MANUAL TM 11-400A			2		
6740-408-5005						BATTERY BA-42 (Not installed)			2		
6760-498-9952						BOARD PH-317A (Not installed)			1		
6720-515-0342						CABLE RELEASE PH-308 (Not installed)			1		
6760-286-7881						CAMERA, STILL PICTURE KE-7(1) (Not installed)		NX	1		
6740-224-9586						CARRYING CASE, PHOTOGRAPHIC EQUIPMENT FM-22(1) (Not installed).		NX	1		
8305-281-2884						CLIP PH-165 (Not installed)			6		
6760-570-9225						CLOTH, TEXTILE: Fed spec #CCC-C-271, type #11, (Not installed).			1		
6640-752-7678						FLASH, GUN PHOTOGRAPHIC: Kalert Model No. BC-421 (Not installed).		NX	1		
6760-810-8385						GRADUATE PH-11 (Not installed)			1		
6640-393-2090						METER, PHOTOGRAPHIC LM-46A (Not installed)			1		
6740-292-9675						PAPER LENS: Fed spec No. UU-P-313 (Not installed)			1		
6740-550-2112						PRINTER, PROJECTION PHOTOGRAPHIC EN-11(1) and EN-11(2) (Installed in equip).		NX	1		
7510-161-6215						ROD, STIRRING: spec MIL-RX10618 (Not installed)			2		
						RULE: (Not installed)			1		

Federal stock number	Designation by model						Description	Unit of issue	Exp	Qty auth	Illustration	
											Fig. No.	Item No.
7920-240-2561	--	--	--	--	--	--	SPONGE, CELLULOSE: Fed spec #L-S-626, type #11 (Not installed).	--	--	1		
6740-224-9565	--	--	--	--	--	--	TANK PH-322: (Not installed)	--	--	1		
6760-521-0656	--	--	--	--	--	--	THERMOMETER PH-28 (Not installed)	--	--	1		
6645-243-9470	--	--	--	--	--	--	TIMER FM-103(1) (Not installed)	--	--	1		
6740-243-2941	--	--	--	--	--	--	TRAY PH-158-A (Not installed)	--	--	3		
RUNNING SPARE ITEMS												
6780-408-5390	--	--	--	--	--	--	CLAMP: Ekco "Kodapod" #U-10269 (Not installed)	--	--	1		
6760-356-5481	--	--	--	--	--	--	FILTER, LIGHT: Enteco Industries #5023 (Not installed)	--	--	1		
6760-523-6090	--	--	--	--	--	--	LENS, SUPPLEMENTARY: Enteco Industries Proxar #5032 (Not installed).	--	--	1		
6760-597-1427	--	--	--	--	--	--	LENS, SUPPLEMENTARY: Enteco Industries Proxar #5031 (Not installed).	--	--	1		
6640-393-2090	--	--	--	--	--	--	PAPER LENS: Fed spec No. UU-P-313 (Not installed)	--	--	5		
6760-318-6802	--	--	--	--	--	--	RING, RETAINING: Inteco Industries #5016 (Not installed).	--	--	1		
6720-533-6353	--	--	--	--	--	--	RING, ADAPTER: Enteco Industries #5044 (Not installed)	--	--	1		

		PRINTER PROJECTION, PHOTOGRAPHIC EN-11(1); EN-11(2)						
		NOTE: Model Column 1 refers to EN-11(1); Column 2 refers to EN-11(2)						
		ITEMS COMPRISING AN OPERABLE EQUIPMENT						
6760-664-4013	-- †	--	--	--	CAP LENS: Elgeet Optical Co. p/n 2313 (Installed in equip).	----	----	1
6740-318-6797	† †	--	--	--	CARRIER, NEGATIVE: Testrite Instrument Co. p/n EN-21 (Not installed).	----	----	1
6760-201-1302	†	--	--	--	FILTER, LIGHT: SunRay p/n EN-29 (Installed in equip)	----	----	1
6760-958-7406	-- †	--	--	--	FILTER LIGHT: Testrite Instrument Co. p/n EN-29 (Not installed).	----	----	1
6760-959-1519	-- †	--	--	--	HOLDER, FILTER: Testrite Instrument Co. p/n EN27 (Installed in equip).	----	----	1
6240-237-7876	† †	--	--	--	LAMP, INCANDESCENT; GE #PH/113 (Installed in equip).	----	----	1
6760-397-3540	†	--	--	--	LENS, PROJECTION: Wollensak Rapter Enlarger Lens (Installed in equip).	----	----	1
6760-958-7397	-- †	--	--	--	LENS, PROJECTION PRINTING: Elgeet Optical Co. p/n E5145 (Installed in equip).	----	----	1
		RUNNING SPARE ITEMS						
6760-201-1302	†	--	--	--	FILTER, LIGHT: SunRay p/n EN-29 (Installed in equip)	----	----	
6240-237-7876	† †	--	--	--	LAMP, INCANDESCENT: GE #PH-113 (Not installed)	----	----	1

By Order of the Secretary of the Army:

HAROLD K. JOHNSON,
General, United States Army,
Chief of Staff.

Official:

J. C. LAMBERT,
Major General, United States Army,
The Adjutant General.

Distribution:

Active Army:

USASA (2)	Svc Colleges (2)
CNGB (1)	Br Svc Sch (2)
CofEngrs (1)	AV Comm Cen (5)
TSG (1)	GENDEP (OS) (2)
CC-E (7)	Sig Sec, GENDEP (OS) (5)
CofT (1)	Sig Dep (OS) (12)
CofSpts (1)	Army Dep (2) except
USCONARC (5)	FTWOAD (10)
USAMC (5)	LXAD (14)
ARADCOM (2)	SAAD (30)
ARADCOM Rgn (2)	TOAD (14)
OS Maj Comd (3)	LEAD (5)
LOGCOMD (2)	SHAD (3)
USAECOM (7)	SVAD (5)
USASMCOM (2)	NAAD (5)
USAMICOM (4)	CHAD (3)
USACDCEA (2)	ATAD (4)
USACDCCBRA (1)	USACDCCEA (2)
USACDCOA (1)	USAERDAW (13)
USACDCQMA (1)	USAERDAA (10)
USACDCTA (1)	POE (1)
USACDCADA (1)	Trans Tml Comd (1)
USACDCARMA (1)	Army Tml (1) except
USACDCAVNA (1)	Oakland Army Tml (5)
USACDCARTYA (1)	AMS (1)
USACDCSWA (2)	WRAMC (1)
USASCC (4)	Army Pictorial Cen (2)
MDW (1)	Chicago Proc Dist (1)
Armies (2)	Sig Fld Maint Shops (2)
Corps (2)	11th Air Assault Div (3)
USA Corps (3)	WSMR (5)
USATC AD (2)	Units org under fol TOE:
USATC Engr (3)	(2 copies each UNOINDC)
USATC Inf (2)	5-15
USATC Armor (2)	5-16
USASTC (3)	5-35
Instls (2) except	5-36
Fort Hancock (4)	5-97
Fort Monmouth (63)	5-225
Fort Gordon (5)	5-226

11-16	19-36
11-57	19-217
11-96	19-500 (AA-AE)
11-97	29-56
11-98	30-17
11-117	30-18
11-155	30-25
11-157	30-26
11-337	30-500 (AA-AE)
11-500 (AA-AE) (4)	39-51
11-557	39-52
11-587	39-62
11-592	54-102
11-597	54-202
19-35	57

NG: State AG (3).

USAR: None.

For explanation of abbreviations used, see AR 320-50.

TECHNICAL MANUAL
PHOTOGRAPHIC SET ES-12(1)

TM 11-400A }
CHANGE NO. 1 }

HEADQUARTERS
DEPARTMENT OF THE ARMY
WASHINGTON, D. C., October 1, 1963

TM 11-400A, 6 January 1955, is changed as follows:

Page 3, section I. Delete section and substitute:

Section I. GENERAL

1. Scope

This manual describes Photographic Set ES-12(1) and covers its installation, operation, maintenance, and repair. It includes operation under usual and unusual conditions, cleaning and inspection of the equipment, and instructions for replacement of specified maintenance parts. The theory of operation of the equipment is covered in paragraphs 28 through 33.

2. Index of Publications

Refer to the latest issue of DA Pam 310-4 to determine whether there are new editions, Changes, or additional publications pertaining to this equipment. DA Pam 310-4 is an index of current technical manuals, technical bulletins, supply bulletins, lubrication orders, and modification work orders that are available through publications supply channels. The index lists the individual parts (-10, -20, -35P, etc.) and the latest changes to and revisions of each equipment publication.

2.1 Forms and Records

a. Reports of Maintenance and Unsatisfactory Equipment. Use equipment forms and records in accordance with instructions in TM 38-750.

b. Report of Damaged or Improper Shipment. Fill out and forward DD Form 6 (Report of Damaged or Improper Shipment) as prescribed in AR 700-58 (Army), NAVSANDA Publication No. 378 (Navy), and AFR 71-4 (Air Force).

c. Reporting of Equipment Manual Improvements. The direct reporting by the individual user, of errors, omissions, and recommendations for improving this manual is authorized and encouraged. DA Form 2028 (Recommended changes to DA technical manual parts lists or supply manual 7, 8 or 9) will be used for reporting these improvement recommendations. This form will be completed in triplicate using pen-

cil, pen, or typewriter. The original and one copy will be forwarded direct to: Commanding Officer, U. S. Army Electronics Materiel Support Agency, ATTN: SELMS-MP, Fort Monmouth, N.J., 07703. One information copy will be furnished to the individual's immediate supervisor (officer, noncommissioned officer, supervisor, etc.).

Page 19, paragraph 8c. Delete subparagraph c. Add paragraph 8.1 after paragraph 8.

8.1. Checking Unpacked Equipment

a. Inspect the equipment for damage incurred during shipment. If the equipment has been damaged, report the damage on DD Form 6 (par. 2.1).

b. See if the equipment is complete as listed on the packing slip. If a packing slip is not available, check the equipment against the table of components (par. 3b). Report all discrepancies in accordance with TM 38-750. Shortage of a minor component or part that does not affect proper functioning of the equipment should not prevent use of the equipment.

c. If the equipment has been used or reconditioned, see whether it has been changed by a modification work order (MWO). If the equipment has been modified, the MWO number will appear near the nomenclature plate. Check to see whether the MWO number (if any) and appropriate notations concerning the modification have been entered in the equipment manual.

Note. Current MWO's applicable to the equipment are listed in DA Pam 310-4.

Page 52, chapter 4. Make the following changes:

Heading. Delete "ORGANIZATIONAL".

Delete sections I and II and substitute:

Section I. OPERATOR'S MAINTENANCE

19. Scope of Operator's Maintenance

The maintenance duties assigned to the operator of Photographic Set ES-12(1) are listed below together with a reference to the paragraphs covering the specific maintenance functions. The duties assigned do not require tools or materials other than those specified in paragraph 20.

a. Daily preventive maintenance checks and services (par. 23).

b. Weekly preventive maintenance checks and services (par. 24).

c. Cleaning (par. 24.1).

20. Tools and Materials Required

The following tools and materials are required to perform operator's preventive maintenance.

- a. Lint-free cloth (FSN 8305-170-5062).
- b. Hand-blower (air syringe).
- c. Camel's-hair brush.
- d. Lens cleaner (FSN 6760-408-5175).
- e. Lens tissue (FSN 6640-393-2090).
- f. Cleaning compound (FSN 7930-395-9542).

21. Operator's Preventive Maintenance

Preventive maintenance is the systematic care, servicing, and inspection of equipment to prevent the occurrence of trouble, to reduce downtime, and to assure that the equipment is serviceable.

a. *Systematic Care.* The procedures given in paragraphs 23, 24, and 24.1 cover routine systematic care and cleaning essential to proper upkeep and operation of the equipment.

b. *Preventive Maintenance Checks and Services.* The preventive maintenance checks and services charts (par. 23 and 24) outline functions to be performed at specific intervals. These checks and services are to maintain equipment in a combat serviceable condition; that is, in good general (physical) condition and in good operating condition. To assist operators in maintaining combat serviceability, the charts indicate what to check, how to check, and what the normal conditions are. The *References* column lists the location of additional data or procedures. If a defect is noted that cannot be remedied by the operator, higher echelon maintenance is required. Records and reports of these checks and services must be made in accordance with the requirements set forth in TM 38-750.

22. Operator's Preventive Maintenance Checks and Services Periods

a. *Daily.* Preventive maintenance checks and services of Photographic Set ES-12(1) are required on a daily basis while the equipment is in use. If the equipment is being maintained on a *standby* (ready for immediate operation) condition, the daily checks and services should be performed once each week. Paragraph 23 specifies the checks and services that must be accomplished daily and under the following special conditions:

- (1) When the equipment is initially placed in service.
- (2) Before the start of a mission.
- (3) When the equipment or any of its major components is removed from service for any reason.

b. *Weekly.* Perform the maintenance functions indicated in the weekly preventive maintenance checks and services chart (par. 24) once

each week at the same time as the daily maintenance checks and services (par. 23). A week is defined as approximately 7 calendar days of 8-hour-per-day operation. If the equipment is operated more than 8 hours a day, the weekly maintenance interval should be adjusted. Adjustment of the weekly maintenance interval should also be made to compensate for any unusual operating conditions. Equipment maintained in a *standby* condition must have weekly maintenance performed on it. Equipment in *limited storage* (requires service before operation) does not require weekly maintenance.

23. Daily Preventive Maintenance Checks and Services Chart

Sequence No.	Item	Procedure	References
1	Optical surfaces ...	<p>Caution: Do not attempt to disassemble lenses to remove foreign matter from between the lens elements. If internal cleaning is required, refer equipment to higher echelon for correction.</p> <p>Remove dust and dirt from exposed optical surfaces.</p>	Par. 24.1a.
2	Controls and indicators.	Examine knobs, levers, and handles of controls and indicators for bent, broken, and damaged parts. Control knobs, levers, and handles must be firmly secured (fig. 2).	
3	Carrying case	Examine carrying case straps (fig. 3), cover, snaps, and lock for positive action. Check to be sure that carrying case is not broken or otherwise damaged.	
4	Safelight	Inspect safelight (18, fig. 2) lamp; replace if necessary.	
5	Timer	Inspect timer (17, fig. 2) for damaged glass, dirt, dust, loose or missing screws, and winding keys.	Appx.
6	Copy lights	Inspect copy light (fig. 16) lamps; replace if necessary. Check cable insulation. Clean copy light reflectors.	Par. 24.1c.
7	Flash synchronizer.	Check flash synchronizer test lamp (par. 12b); replace if necessary.	
8	Reflector battery case.	Check reflector battery case (1, fig. 1), interior and exterior, for corrosion, dirt, or other foreign matter.	Par. 24.1b.

Sequence No.	Item	Procedure	References
9	Batteries	Check batteries (fig. 11) for clean contacts.	Par. 12b.
10	Printer (exterior)...	Inspect for damaged baseboard, dust, dirt, and loose or missing screws.	Par. 24.1b and c.
11	Printer lamphouse.	Remove dust, dirt, mildew, or fingerprints.	Par. 24.1a, b, and c.
12	Camera	Check condition of camera.	Appx.
13	Exposure meter...	Check condition of exposure meter.	Appx.
14	Operation	During operation, be alert for any unusual operating conditions.	

24. Weekly Preventive Maintenance Checks and Services Chart

Sequence No.	Item	Procedure	References
1	Overall equipment; check for: a. Completeness. b. Cleanliness... c. Equipment markings.	a. Check to see that equipment is complete (par. 3b). b. Check to see that all accessible parts and components are clean, dry, and free of foreign matter. c. Check to see that all equipment markings and control and indicator markings are legible.	a. None. b. Par. 24.1. c. None.
2	Power cable	Examine power cable for signs of deterioration or frayed or cut insulation.	
3	Connectors and receptacles.	Examine all connectors and receptacles for signs of loose contacts; remove all dirt and corrosion.	Par. 24.1b.
4	Minor components.	Check minor components (fig. 2) for signs of wear and breakage.	
5	Camera and exposure meter.	Perform weekly preventive maintenance checks and services procedures.	Appx.

24.1. Cleaning

a. *Optical Surfaces.* Clean the optical surfaces of the equipment as follows:

- (1) Carefully remove all dust, dirt, and foreign matter from the

exposed optical surfaces of the equipment; use a camel's-hair brush or an air syringe.

Caution: Do not use lens tissue that contains silicone to clean optical surfaces. Use only the lens tissue authorized for use with the equipment (par. 20). Any residue left on the optical surfaces by lens tissue that contains silicone could affect the performance of the optical parts.

- (2) Slightly dampen a wad of lens tissue with lens cleaner.
- (3) Gently wipe the exposed optical surfaces of the camera with the moistened lens tissue; use a circular motion starting from the edge of the glass and working toward the center.
- (4) Dry the cleaned optical surfaces with a fresh lens tissue, using the circular motion described in (3) above.

b. Exterior Surfaces. Clean the exposed metal surfaces (except items such as trays and reflector surfaces) of the equipment as follows:

- (1) Remove dust and dirt from all exposed metal surfaces with a dry, lint-free cloth.
- (2) Use a camel's-hair brush or an air syringe to remove dust, dirt, and foreign matter from hard-to-reach parts.

Warning: Cleaning compound is flammable and its fumes are toxic. Do not use near a flame and provide adequate ventilation.

Caution: Do not allow the cleaning compound to come in contact with optical surfaces. Use cleaning compound sparingly.

- (3) If foreign matter cannot be removed from the mechanical parts by normal dry wiping, use a clean, lint-free cloth slightly moistened with cleaning compound. Wipe the cleansed parts with a clean, dry, lint-free cloth immediately after cleaning.

c. Reflector Surfaces. Clean the reflector surfaces of the equipment as follows:

- (1) Remove dust and dirt from the reflector surfaces with an air syringe.
- (2) If additional cleaning is required, use a lint-free cloth dampened with water. After cleaning, wipe the surface with a clean, dry, lint-free cloth.

d. Miscellaneous Components. Clean the processing tank, trays, stirring rods, glass graduate, and thermometer as follows:

- (1) Thoroughly rinse in clean water.
- (2) If necessary, wash with mild soap and water and then rinse with clean water.
- (3) After cleaning, wipe with a clean, dry, lint-free cloth.

Section II. ORGANIZATIONAL (SECOND ECHELON) MAINTENANCE

24.2. Scope of Organizational Maintenance

The maintenance duties assigned to organizational maintenance personnel of Photographic Set ES-12(1) are listed below together with a reference to the paragraphs covering the specific maintenance functions.

- a. Monthly preventive maintenance checks and services (par. 24.5).
- b. Quarterly preventive maintenance checks and services (par. 24.7).
- c. Lubrication (par. 24.8).
- d. Troubleshooting (par. 25, 26, and 27).

24.2. Tools, Materials, and Test Equipment Required

In addition to the tools and materials listed in paragraph 20, the following items are required:

- a. Tool Kit, Photographic Repair TK-77/GF.
- b. Sandpaper (No. 000).
- c. Oil, Lubricating, Preservative Special (PL SPECIAL) (FSN 9150-185-0629).
- d. Grease, Aircraft and Instrument (GL) (FSN 9150-261-8297).

24.3. Organizational Preventive Maintenance

a. Organizational preventive maintenance is the systematic care, inspection, and servicing of equipment to maintain it in serviceable condition, prevent breakdowns, and assure maximum operational capability. Preventive maintenance is the responsibility of all echelons concerned with the equipment and includes the inspection, testing, and repair or replacement of parts, subassemblies, or units that inspection and tests indicate would probably fail before the next scheduled periodic service. Preventive maintenance checks and services of the equipment at the second echelon level are made at monthly and quarterly intervals at the same time as the daily (par. 23) and weekly (par. 24) preventive maintenance checks and services unless otherwise directed by the commanding officer.

b. Maintenance forms and records to be used and maintained on this equipment are specified in TM 38-750.

24.4. Monthly Maintenance

Perform the maintenance functions indicated in the monthly preventive maintenance checks and services chart (par. 24.5) once each month. A month is defined as approximately 30 calendar days of 8-hour-per-day operation. If the equipment is operated 16 hours a day,

the monthly preventive maintenance checks and services should be performed at 15-day intervals. Adjustment of the maintenance interval must be made to compensate for any unusual operating conditions. Equipment maintained in a *standby* condition must have monthly preventive maintenance checks and services performed on it. Equipment in *limited storage* does not require monthly preventive maintenance.

24.5. Monthly Preventive Maintenance Checks and Services Chart

Sequence No.	Item	Procedure	References
1	Preservation	<p>a. Check all exterior surfaces for evidence of fungus, rust, and corrosion.</p> <p>b. Remove rust and corrosion from metal surfaces by lightly sanding them with fine sandpaper. Brush two thin coats of paint on the bare metal to protect it from further corrosion.</p>	<p>a. Par. 43.</p> <p>b. TM 9-213.</p>
2	Lens mountings...	Inspect lens mountings (fig. 25) for proper seating and firm mounting.	
3	Doors and covers..	Check doors and covers for tight closure and effective light sealing.	
4*	Lubrication	Lubricate support column (fig. 25) and friction wheel knob.	Par. 24.8.
5	Camera and exposure meter.	Perform monthly preventive maintenance checks and services procedures.	Appx.

* To be accomplished every 500 hours instead of monthly.

24.6. Quarterly Maintenance

Quarterly preventive maintenance checks and services on the equipment are required. Periodic daily (par. 23), weekly (par. 24), and monthly (par. 24.5) preventive maintenance checks and services constitute a part of the quarterly preventive maintenance checks and services and must be performed concurrently. All deficiencies or shortcomings will be recorded in accordance with the requirements of TM 38-750. Perform all the checks and services listed in the quarterly preventive maintenance checks and services chart (par. 24.7) in the sequence listed.

24.7. Quarterly Preventive Maintenance Checks and Services Chart

Sequence No.	Item	Procedure	References
1	Publications	See that all publications are complete, serviceable, and current.	DA Pam 310-4.
2	Modifications	Check DA Pam 310-4 to determine if new applicable MWO's have been published. All URGENT NWO's must be applied immediately. All NORMAL MWO's must be scheduled.	TM 38-750 and DA Pam 310-4.
3	Operation	Operate equipment in accordance with instruction in equipment performance checklist (par. 27)	Par. 27 and appx.

24.8. Lubrication

The support column and the friction wheel knob of the printer require lubrication every 500 operating hours. Lubricate the printer, as follows:

Caution: Make sure that oil and grease do not come in contact with any optical surfaces. If necessary, clean the optical surfaces (par. 24a) after lubricating the printer.

a. Wipe the support column with a clean, lint-free cloth lightly dampened with oil (PL Special).

b. Wipe the friction wheel knob with a clean dry cloth; then, coat it lightly with grease (GI).

Page 57, paragraph 25, line 5. Delete the fourth sentence.

Page 65, Delete paragraphs 35 and 36.

Page 78. Add the following appendix after paragraph 48.

APPENDIX REFERENCES

Following is a list of applicable references available to maintenance man of Photographic Set ES-12(1):

DA Pam 310-4	Index of Technical Manuals, Technical Bulletins, Supply Bulletins, Lubrication Orders, and Modification Work Order.
TM 9-213	Painting Instructions for Field Use.
TM 11-401	Elements of Signal Photography.

TM 11-405-10	Operator's Manual: Processing Equipment PH-406 and Photographic Film Processing Unit ES-20(1).
TM 11-487F	Directory of U.S. Army Signal Equipment: Pictorial Equipment.
TM 11-2361	Camera PH-324.
TM 11-2361A	Camera PH-324-A.
TM 11-2361B	Still Picture Camera KE-7(1).
TM 11-5527	Multimeters TS-352/U, TS-352A/U, and TS-352B/U.
TM 11-6720-206-12	Operator and Organizational Maintenance Manual: Meter, Photographic Exposure LM-46A.
TM 38-750	The Army Equipment Record System and Procedures.

By Order of the Secretary of the Army:

EARLE G. WHEELER,
General, United States Army,
Chief of Staff.

Official:

J. C. LAMBERT,
Major General, United States Army,
The Adjutant General.

Distribution:

Active Army:

DASA (6)	Armies (2)
USASA (2)	Corps (2)
CNGB (1)	USA Corps (3)
CofEngrs (1)	USATC AD (2)
TSG (1)	USATC Inf (2)
CSigO (7)	USATC Armor (2)
CofIT (1)	USASTC (5)
CofSptS (1)	Instl (2) except
USA CD Agcy (1)	Ft Monmouth (65)
USCONARC (5)	Svc Colleges (2)
USAMC (5)	Br Svc Sch (2) except
ARADCOM (2)	GENDEP (OS) (2)
ARADCOM Rgn (2)	Sig Dep (OS) (12)
OS Maj Comd (3)	Sig Sec, GENDEP (5)
OS Base Comd (2)	Army Dep (2) except
LOGCOMD (2)	Ft Worth (8)
USAECOM (5)	Lexington (12)
USAMICOM (4)	Sacramento (28)
USASCC (4)	Tobyhanna (12)
MDW (1)	USA Trans Tml Cmd (1)

Army Tml (1)	11-57
USAOSA (1)	11-96
POE (1)	11-117
WRAMC (1)	11-155
AMS (1)	11-157
AFIP (1)	11-500 (AA-AE) (4)
Army Pic Cen (2)	11-557
USA Mbl Spt Cen (1)	11-587
USA Elct Mat Agcy (12)	11-592
Chicago Proc Dist (1)	11-597
USA Elct RD Actv,	17
White Sands (13)	19-35
USA Elct RD Actv,	19-36
Ft Huachuca (2)	19-217
USARSOUTHCOM Sig	19-500 (AA-AE)
Agcy (1)	29-56
Sig Fld Maint Shop (3)	30-14
Units org under fol TOE:	30-15
(2 copies UNOINDC)	30-17
5-15	30-18
5-16	30-25
5-35	30-26
5-36	30-500 (AA-AE)
5-97	39-51
5-225	39-52
5-226	39-62
7	54-102
11-7	54-202
11-16	57

NG: State AG (3).

USAR: None.

For explanation of abbreviations used, see AR 320-50.

TECHNICAL MANUAL }
 No. 11-400A }

DEPARTMENT OF THE ARMY
 WASHINGTON 25, D. C., 6 January 1955

PHOTOGRAPHIC SET ES-12 (1)

	<i>Paragraph</i>	<i>Page</i>
CHAPTER 1. INTRODUCTION		
Section I. General	1,2	3
II. Description and data	3-7	3-16
CHAPTER 2. INSTALLATION	8,9	19,20
3. OPERATION		
Section I. Control and operation under usual conditions- -	-10-15	22-44
H. Operation under unusual conditions	16-18	50-51
CHAPTER 4. ORGANIZATIONAL MAINTENANCE		
Section I. Preventive maintenance services	19-22	52-54
II. Lubrication and weather-proofing	23,24	56
III. Troubleshooting at organizational maintenance level	25-27	57
CHAPTER 5. THEORY	28-33	62-63
CHAPTER 6. FIELD MAINTENANCE		
Section I. Inspecting, stripping, and cleaning	34-36	64-65
II. Troubleshooting at field maintenance level	37,38	66
III. Repairs	39-43	68-73
IV. Final testing	44,45	74,75
CHAPTER 7. SHIPMENT AND LIMITED STORAGE AND DEMOLITION TO PREVENT ENEMY USE	46-48	76-77
INDEX		79

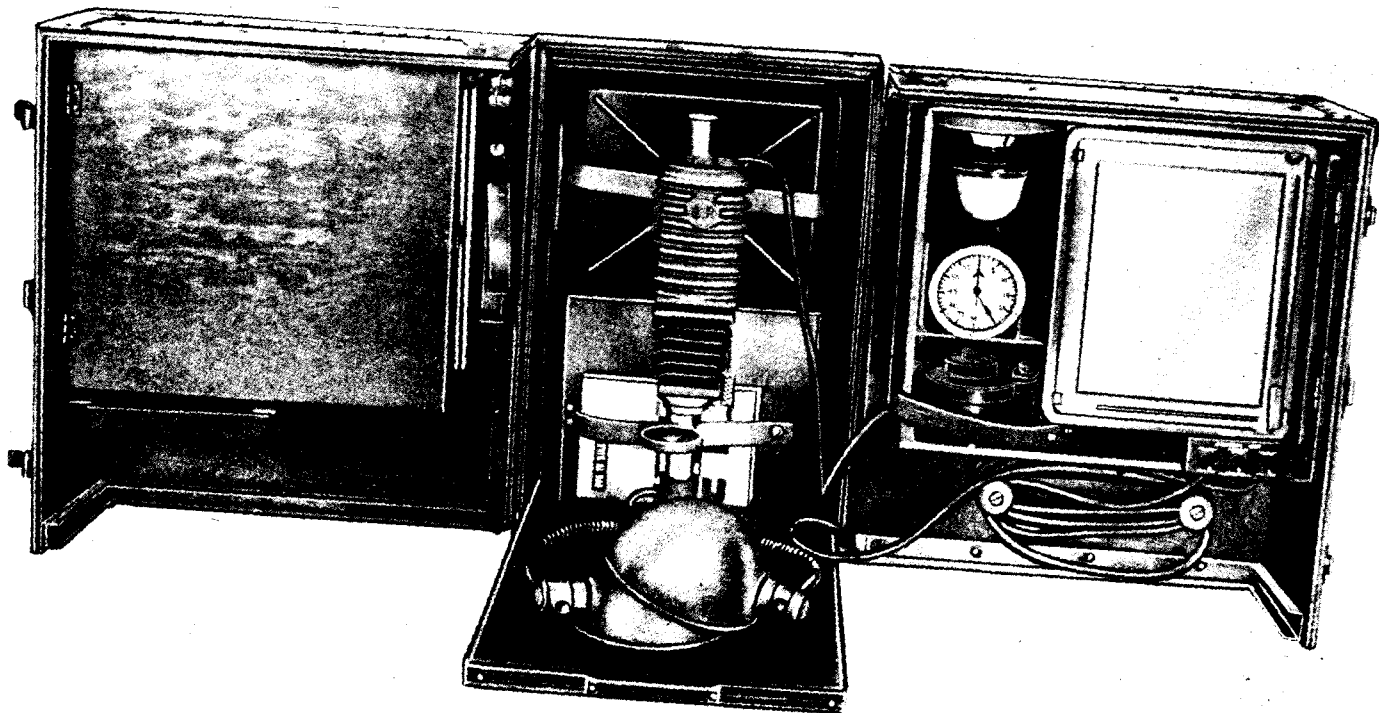

Figure 1. Photographic Set ES-12 (1), case open.

TM 400A-1

CHAPTER 1

INTRODUCTION

Section I. GENERAL

1. Scope

a. This manual contains instructions for the installation, operation, maintenance, and repair of Photographic Set ES-12 (1). A chapter on the theory of operation of the equipment also is included. These instructions apply only to Photographic Set ES-12 (1).

b. Forward comments on this publication directly to Commanding Officer, The Signal Corps Publications Agency, Fort Monmouth, N. J., ATTN: Standards Branch.

2. Forms and Records

The following forms will be used for reporting unsatisfactory conditions of Army equipment:

a. DD Form 6, Report of Damaged or Improper Shipment, will be filled out and forwarded as prescribed in SR 745-45-5 (Army); Navy Shipping Guide, Article 1850-4 (Navy) ; and AFR 714 (Air Force).

b. DA Form 468, Unsatisfactory Equipment Report, will be filled out and forwarded to the Office of the Chief Signal Officer, as prescribed in SR 700-45-5.

c. DD Form 535, Unsatisfactory Report, will be filled out and forwarded, as prescribed in SR 700-45-5 and AF to 00-35D-54.

d. Use other forms and records as authorized.

Section II. DESCRIPTION AND DATA

3. Photographic Set ES-12 (1)

a. General (figs. 1 and 2). Photographic Set ES-12 (1) is an assembly of equipment, chemicals, and other materials (*b* below) used to take photographs, to process film and enlarging papers, and to make copy prints. It is used to produce and process projection prints from processed 35-millimeter (mm) still-camera film. The equipment is portable and it is intended primarily for field use.

b. Table of Components (fig. 2). The following list is for general information only. See appropriate supply publications for information pertaining to requisition of spare parts.

Item No.	Component	Quantity	Dimensions (in.)			Dia. (in.)	Unit weight
			Height	Width	Length		
14	Photographic Equipment Carrying Case FM-22 (1)-----	1	22½	16½	24		60 lb.
26	1 Case cover-----		23	17	24½		1 lb 12 oz.
25	1 Case strap-----			1½	96		8 oz.
18	1 Safelight-----		3½			¾	2 oz.
17	1 Timer PH-29-----				3	4	1 lb 3 oz.
30	2 Copy lights-----		3½		16	6½	2 lb 8 oz.
24	1 Power cable-----				20 ft		
11	Camera PH-324-A-----	1	2 ¹ / ₁₆	2 ¹ / ₂	4 ³ / ₁₆		15 oz.
31	1 Case PH-371-A-----		3 ³ / ₁₆	3	5		5 oz.
19	Flash synchronizer-----	1	5½	3½	3½		12 oz.
42	Camera mounting clamp-----	1	¾	2	1½		15 oz.
37	Adapter ring-----	1			5/16	1½	1 oz.
35	Retaining ring-----	1			5/16	1¼	1 oz.
38	Lens hood-----	1			½	1¼	1½ oz.
39	Portrait lens, 1-plus-----	1			3/16	1 ³ / ₁₆	¼ oz.
40	Portrait lens, 2-plus-----	1			3/16	1 ³ / ₁₆	¼ oz.
34	Filter K2-----	1			3/16	1 ³ / ₁₆	¼ oz.
6	Film, 35-mm (microfilm)-----	6			2½	1¼	3 oz.
6	Film, 35-mm (high speed, panchromatic)-----	12			2½	1¼	3 oz.
36	Cable Release PH-308-----	1			7	¾	½ oz.
7	Exposure Meter PH-260-A-----	1			3¾		9½ oz.
16	Photographic Projection Printer EN-11 (1)-----	1	18½	4	14½		7 lb.
	Board PH-317-A-----	1	¾	10¼	12½		3 lb 4 oz.
2	Developer (fine grain)-----	6	¾	3	4		2¼ oz.
3	Developer (M-Q Universal, pkg)-----	18	2½	2½	1½		2¼ oz.
1	Hardener and fixer-----	6	4			2½	6 oz.

8	Graduate PH-11	1	6			3 1/8	1 lb 1/2 oz.
22	Rod PH-230	2			10	1/4	1 oz.
20	Tank PH-322	1	4	5 1/4	7 1/2		1 lb 8 oz.
10	Thermometer PH-28	1	4 1/2	1 1/16			1 oz.
27	Tray PH-158-A	3	2 1/4	10 1/4	12 1/2		1 lb 2 oz.
9	Viscose sponge	1	1 1/2	5	3		1/2 oz.
32	Clip PH-165	6	5	2 1/4	1 1/4		1 oz.
13	Ruler (12-inch)	1		1 1/8	12		2 oz.
28	Blotters (photo)	30		8 1/4	10 1/4		16 oz.
23	Enlarging paper (grade 2, pkg)	3		8	10		10 oz.
23	Enlarging paper (grade 3, pkg)	3		8	10		10 oz.
4	Lamp (7 w, safelight)	13	2 1/4			1 1/4	1 oz.
5	Lamp (photo enlarger, 50 w)	13	2 1/4			1 1/4	1 oz.
21	Lamp (photo enlarger, 150 w)	16	4 1/2			2 1/2	3 oz.
15	Lamps (SM photoflash)	16	2 1/2			1 1/8	1/4 oz.
12	Paper (lens tissue pkg)	1		4	6		1/2 oz.
41	Lens cleaner (1 oz bottle)	1	2			1	1 oz.
29	Instruction book: <i>How to Make Good Pictures</i>	1		5 1/2	8		8 oz.
43	Cloth (textile cheesecloth, 25 yd)	1			10	4	16 oz.
33	Batteries (flash)	6			1 1/4	3/8	1 oz.

Note. The item numbers in the above table correspond to the item numbers for figure 2. Board PH-317A is stored inside the compartment door in the right-hand section of the carrying case (fig. 2).

¹ 1 in use, 2 spares.

² 2 in use, 4 spares.

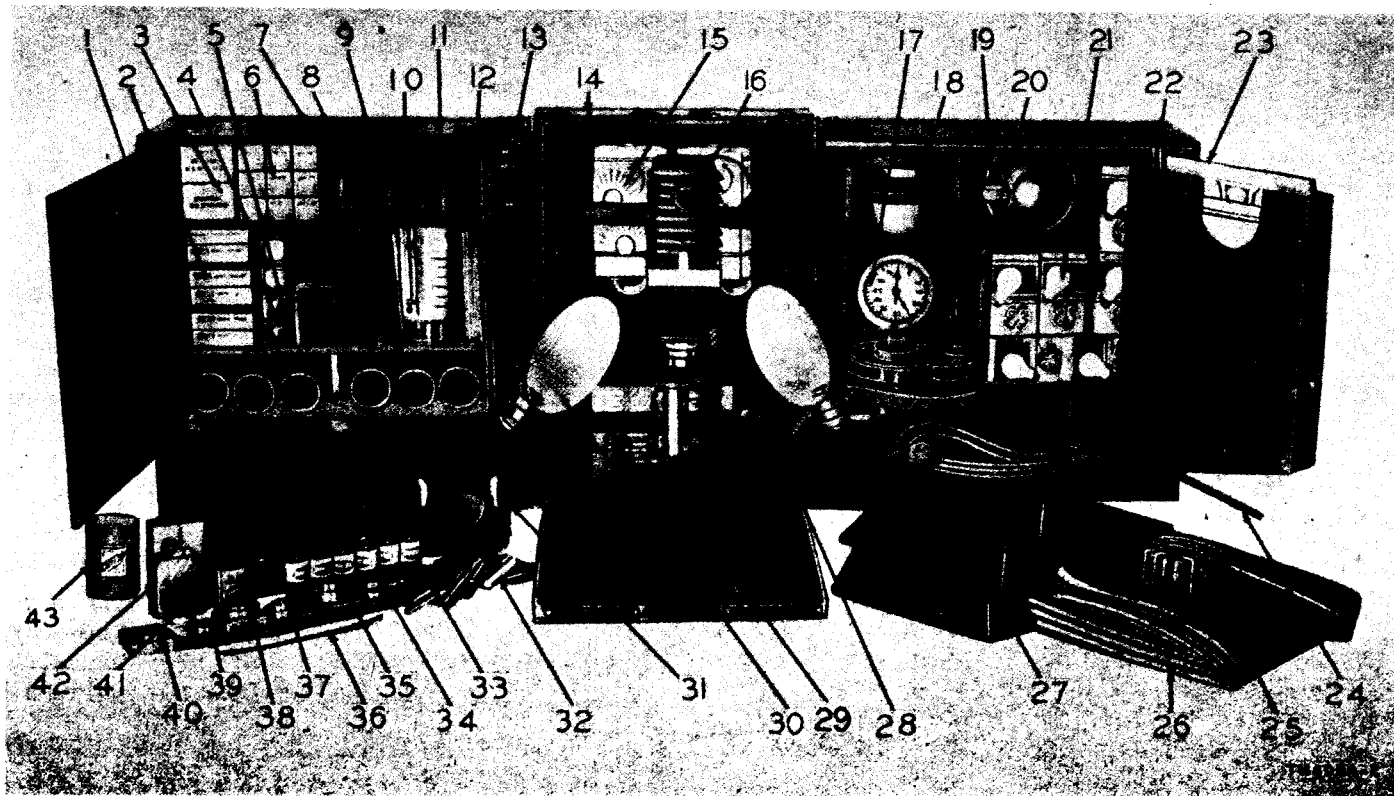

1. Hardener and fixer
2. Developer (fine grain)
3. Developer (M-Q Universal, pkg.)
4. Lamp (7-watt safelight)
5. Lamp (50-watt photo enlarger)
6. High speed panchromatic film, 35-mm (12 rolls). Microfilm, 35-mm (6 rolls)
7. Exposure Meter PH-260-A
8. Graduate PH-11
9. Viscose sponge
10. Thermometer PH-28
11. Camera PH-324-A
12. Paper (lens tissue, pkg.)
13. Ruler (12-inch)
14. Photographic Equipment Carrying Case FM-22 (1)
15. Lamps (SM photo flash)
16. Photographic Projection Printer EN-11 (1)
17. Timer PH-29
18. Safelight
19. Flash synchronizer
20. Tank PH-322
21. Lamp (150-watt photo enlarger)
22. Rod PH-230
23. Enlarging paper (grades 2 and 3, pkg.)
24. Power cable
25. Case strap
26. Case cover
27. Tray PH15B-A
28. Blotters (photo)
29. Instruction book, *How to Make Good Pictures*
30. Copy lights
31. Case PH-371-A
32. Clip PH-165
33. Batteries (flash)
34. Filter K2
35. Retaining ring
36. Cable Release PH-308
37. Adapter ring
38. Lens hood
39. Portrait lens (1-plus)
40. Portrait lens (2-plus)
41. Lens cleaner (1-oz. bottle)
42. Camera mounting clamp
43. Cloth (cheesecloth, 25 yd.)

Figure 2. *Photographic Set ES-12 (1), contents displayed.*

4. Description of Components

a. *Photographic Equipment Carrying Case FM-22 (1)* (figs. 1, 2, and 3). This carrying case is a portable case divided into three sections, with the interior so arranged that all the components and accessories of Photographic Set ES-12 (1) can be packed quickly for moving. The case is constructed of plywood, laminated with hard fiber, and painted olive drab. Timer PH-29, the safelight, copy lights, power cable assembly with control unit (switch box), and two cable pegs are permanent parts of the case. The components and accessories of Photographic Set ES-12 (1) are stored in compartments that have doors and web straps to prevent loss and breakage. Four metal trunk latches and a trunk lock secure the case when it is closed. Metal handles are attached to the sides of the case for carrying.

- (1) *Cover and carrying strap* (fig. 3). The weather protective cover for the case is fabricated of heavy, olive drab, cotton duck. The cover slips over the case and is secured with snap fasteners at the lower edge of both the case and the cover. Overlapping flaps on the sides of the cover permit the strap to be threaded through the metal handles of the case. The 1½-inch by 8 feet long, olive drab, cotton web strap, complete with a metal buckle, is furnished with the cover.

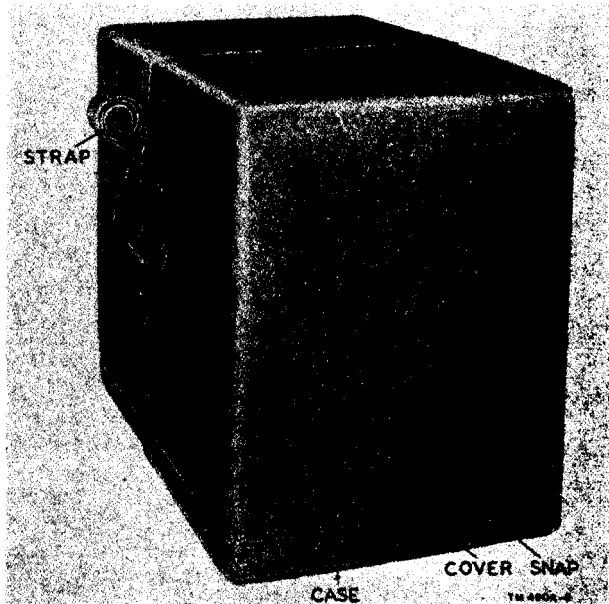

Figure 3. Case closed with cover and strap.

- (2) *Timer PH-29* (fig. 8). This spring-motor-driven timer times processing operations and is graduated to show time intervals from 1 second to 60 minutes. Minute and second hands are pivoted to the center of the calibrated dial, and a start-stop lever is at the base of the dial. The second- and minute hand setting knobs, the speed regulator, and the spring winding knob are located at the back of the timer. The timer is mounted to a hinged bracket in the right hand section of the case.
 - (3) *Safelight* (fig. 2). The safelight is a permanent part of the case and is used when the printer is being operated.
 - (4) *Copy lights* (fig. 2). The copy lights are also a permanent part of the case and provide light when the camera is being used for copying or photographing small objects.
- b. *Camera PH-324-A*. Camera PH-324-A (35-mm still picture) is equipped with a 44-mm, f/3.2 coated lens. For complete information concerning the camera, refer to TM 11-2361A, Camera PH-324-A4.
- c. *Flash Synchronizer* (fig. 11).
- (1) The flash synchronizer consists of a plastic case which holds two size C dry cell batteries and a reflector. Positive electrical contact to the flash bulb is assured by the special conipoint bulb spring. The unit is provided with a test lamp and bulb ejector. It is used with midget bayonet-base type photoflash lamps, and it requires a slight adjustment (par. 12) when used the first time with Camera PH-324-A.
 - (2) The flash synchronizer is mounted on the camera tripod socket by means of an extension bracket. Connection to the camera lens and shutter assembly is made by screwing the synchronizer unit into the cable release socket. Two flashlight batteries are required to operate the synchronizer. Six batteries are supplied with the set.
- d. *Camera Mounting Clamp* (fig. 14). The metal clamp is an accessory device that can be substituted for a tripod when the camera is used outdoors. The clamp is attached to Camera PH-324-A by screwing it into the tripod socket of the camera. Its toothed jaws can grip a small tree, fence, or other wooden objects to hold the camera for exposures longer than 1/25 second.
- e. *Lens Attachments* (fig. 4).
- (1) *Adapter ring*. The metal adapter ring is slipped on over the camera lens mount, and serves as the basic attachment for the retaining ring, filter, or supplementary lens, and lens hood.



Figure 4. Lens attachment.

- (2) *Retaining ring.* The metal retaining ring holds the filter on the supplementary lens in the adapter ring when the lens hood is not used.
- (3) *Lens hood.* The metal lens hood, which shades the camera lens from direct sunlight, can be attached directly to the adapter ring or to the retaining ring when it is used with either the supplementary lens, filter, or both.
- (4) *Filter.* This K2 filter is a yellow gelatin film cemented between two pieces of optical glass and mounted in a metal ring. The yellow color absorbs ultraviolet and some blue-violet rays. It affords correction in daylight with type B panchromatic materials.
- (5) *Supplementary lenses.* These lenses are the 1-plus and 2-plus lenses, which are used for making portraits or photographs of small objects at short distances in order to secure larger images in short focus. They should be used according to table I in paragraph 13d when used for copying.

f. Film (fig. 2). Six rolls of 35-mm microfilm and 12 rolls of 35-mm high-speed panchromatic film of 36 exposures each are supplied with the equipment. The microfilm has an extremely fine-grain, slow, special panchromatic emulsion and is used for making reduced copies of books, manuscripts, line drawings, letters, etc. The high speed panchromatic film is used for general daytime photography or at night with photoflash.

g. Cable Release PH-308 (fig. 2). The cable release is 7 inches long and is actuated by a coil spring around a flexible steel cable, all inclosed in a fabric sleeve. The cable affords vibration-free remote control to the camera shutter release button on Camera PH-324-A, when the camera is operated without the flash synchronizer.

h. Exposure Meter PH-260-A (fig. 2). This light meter may be used in conjunction with Camera PH-324-A. For complete information concerning this meter, refer to TM 11-2356, Exposure Meters PH-260 and PH-260-A.

i. Photographic Projection Printer EN-11 (1) (fig. 5). The printer is a table-size, projection-type printer that makes enlargements of 35-mm photographic negatives. It is mounted onto the laminated plywood baseboard bottom of the carrying case. It is equipped with an f/4.5, 50-mm focal length, coated enlarging lens with an iris diaphragm and a red safety filter. Magnifications from 2.5 to 10 diameters may be obtained when the baseboard is used. Illumination is provided by a bayonet-type, 115- to 125-volt, 50-watt, photo-enlarging lamp which is mounted behind a pair of condenser lenses and a heat-resisting glass. The printer is operated from a 105- to 120-volt alternating current (ac) or direct current (dc) power source.

- (1) *Lamphouse* (fig. 25). The lamphouse is constructed of black, wrinkle-finish, cast-aluminum and consists of a lamphouse body and cover. The lamphouse includes a lampholder, a power cable, and a light-trap baffle with vent openings for the dissipation of warm air so that the printer may be used for extended periods without overheating. The interior of the lamphouse is grooved to accept the condenser system, which is held firmly in position by a baffle plate secured by four screws.
- (2) *Condenser lens set* (fig. 25). The condenser lens set supplied with the printer consists of two clear condenser lenses and a heat-resisting glass.
- (3) *Negative carrier* (fig. 17). The glassless, 35-mm negative carrier is constructed of metal and consists of a top plate, a bottom plate, and a lever. The top and bottom plates of the carrier are hinged. The release movement lever in the front of the carrier permits the strip of film to be moved within the carrier without danger of being scratched. The curved portion at each end of the carrier serves as a film holder.
- (4) *Bellows* (fig. 5). The bellows, mounted between the bellow top plate and the focusing bracket, is made of rubberized black leatherette. The top and bottom ends are folded over a flat plate for lightproof mounting.
- (5) *Bracket* (fig. 5). The bracket is constructed of black, wrinkle-finish, cast-aluminum and is mounted on the printer column. It may be locked at the desired height with the mounting focusing knob. The bracket top includes a mounting screw knob for mounting the printer lamphouse or Camera PH-324-A for copy work.
- (6) *Power cable* (figs. 5 and 28). The power cable is a two-conductor, copper-wire, rubber-coated cord. One end of the cable is connected to the lampholder in the lamphouse and the other end terminates in a standard male plug.

j. Board PH-317-A (fig. 18). The board is used to hold the printing paper during exposure and consists of a backplate, hinged frame, and two adjustable masking arms. Two sides of the frame are calibrated in inches. Maximum printing paper size for this board is 8 by 10 inches. Largest possible print size (masking arms removed) is $7\frac{1}{4}$ by $9\frac{1}{4}$ inches. Smaller print sizes may be masked off by means of the adjusting masking arms.

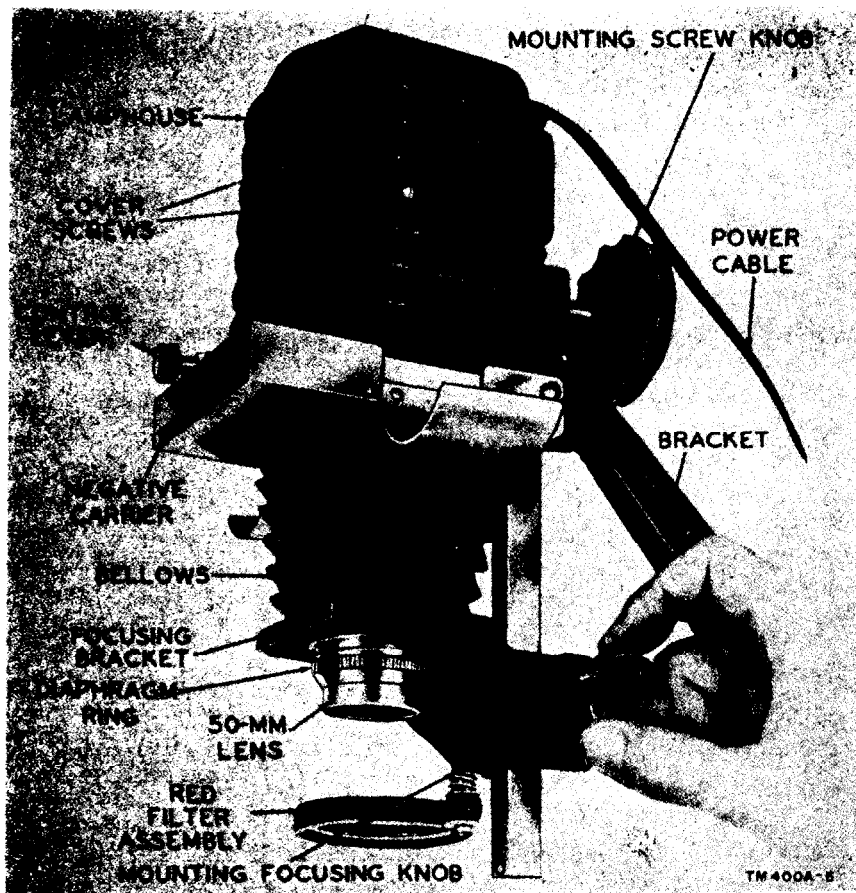

Figure 5. Photographic Projection Printer EN-11 (1).

k. Tank PH-322 (fig. 9). The developing tank is used for daylight processing of 35-mm black and white film when it is contained in daylight loading magazines. The tank is made of black plastic composition and consists of a tank body, magazine chamber knob, and a cover and reel assembly. The reel holds approximately 5 feet (a 36 exposure roll) of film during processing. The processing solutions are poured into, and drained from, the opening at the top of the magazine chamber.

l. Enlarging Paper (fig. 2). Two grades of 8- by 10-inch enlarging paper, No. 2 and No. 3, are supplied with the equipment. The use of these enlarging papers is explained in paragraph 14.

m. Lamps (fig. 2). The following lamps are supplied as accessories and spare parts for Photographic Set ES-12 (1) and are packed with the equipment: 16 SM photoflash lamps, 6 photoenlarger lamps, 3 photoenlarger lamps, and 3 safelight lamps.

n. Miscellaneous Processing Accessories. The following chemicals and accessories are provided for developing and printing of negatives and paper and also to aid in the photographic process:

- (1) Six packages, containing two units each, of fine grain developer (fig. 6) used for fine-grain development.
- (2) Three packages, containing six units each, of Universal M-Q developer.
- (3) Six containers of single powder hardener and fixer.
- (4) Graduate PH-11, a 16-ounce, beaker-shaped glass graduate used for measuring purposes when processing solutions, are prepared.
- (5) Rod PH-230, a 10-inch long, hard-rubber stirring rod. Two rods are used for mixing the processing solutions.
- (6) Three hard-rubber photographic trays (Tray 158-A) used to hold the print processing solutions.
- (7) Thermometer PH-28, a tank and tray thermometer mounted on a metal back. It has a range of 20° to 120° F. It is used for testing temperatures of processing solutions.

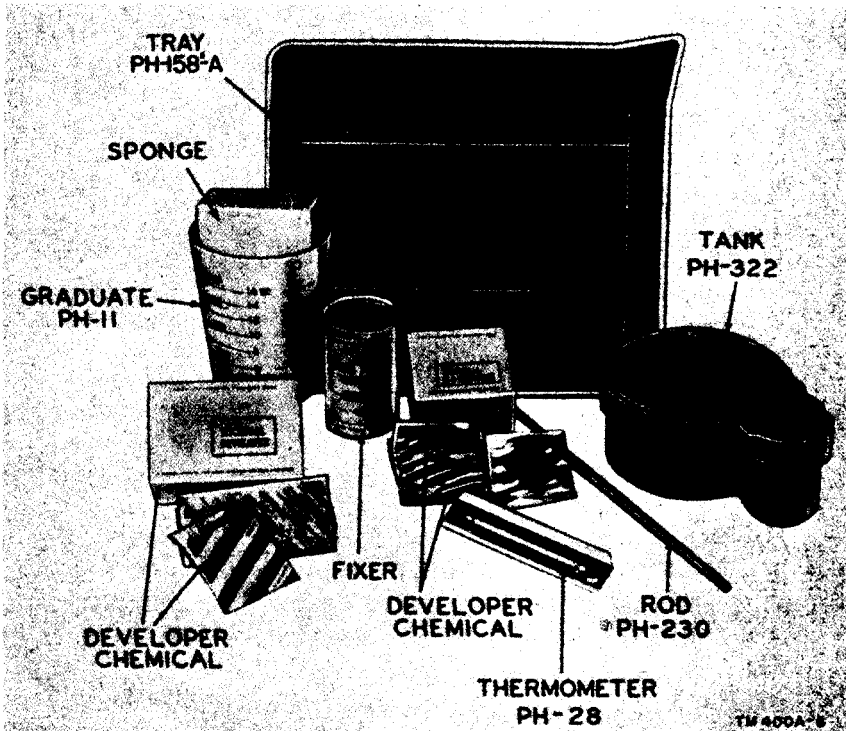

Figure 6. Miscellaneous processing accessories.

- (8) A viscose sponge (fig. 23) for wiping film after developing.
- (9) Six film Clips PH-165 used for hanging film to dry.
- (10) Thirty 8¼- by 10¼-inch photographic blotters (fig. 2) used for drying prints.
- (11) Six packages of paper lens tissue used for cleaning lenses.
- (12) One bottle of lens cleaner used to clean the lenses.
- (13) One 12-inch ruler (fig. 15) used for measuring lens to subject distance when the camera is mounted on the printer column for copying purposes.
- (14) One package of cheesecloth (fig. 2) used for cleaning the equipment.
- (15) One book entitled *How to Make Good Pictures*.

5. Technical Characteristics

The technical characteristics of the principal components of the equipment are listed in *a* through *c* below.

a. Photographic Equipment Carrying Case FM-22 (1).

Type----- Portable.
 Size ----- 24 in. by 16½ in. by 22½ in.
 Weight ----- Approximately 60 lb.
 Special features ----- Built-in electrical control unit with toggle switches for 105 to 120 volts, ac or dc operation.
 Copy lights mounted *on* baseboard inside of case.
 Mounted safelight with 7-watt lamp.
 Timer PH-29, spring motor driven clock mounted *on* hinged bracket in case.

b. Photographic Projection Printer EN-11 (1).

Type----- Projection.
 Negative size ----- 35 mm.
 Enlargements ----- From 2.5 to 10 diameters (when baseboard is used).
 Power source ----- 105 to 120 volts, ac or dc operation.
 Light source ----- 50-watt photo-enlarging, incandescent lamp.
 Condenser lens ----- Two each, 2 3/8-inch dia.
 Heat-resisting glass----- One each, 2 3/8-inch dia.
 Projection lens ----- One 50 mm f/length lens, f/4.5.

c. Tank PH-322.

Type----- Daylight loading.
Film size ----- 35 mm.
Film capacity ----- 36 exposures (approx. 60 in.).
Working temperatures ----- 65° to 75° F.(18° to 21°C.).
Tank capacity ----- 16 oz (solution).

Note. For technical characteristics of Camera PH-324-A, refer to TM 11-2961A; for Exposure Meter PH-260-A, refer to TM 11-2356; for Timer PH-29, refer to TM 11-406, Processing Equipment PH-406.

6. Nomenclature Assignments

A list of nomenclature assignments for Photographic Set ES-12 (1) and its components is given below. A common usage name is indicated for each.

<i>Nomenclature</i>	<i>Common name</i>
Photographic Set ES-12 (1) -----	Photographic set.
Photographic Equipment Carrying Case FM-22 (1) -----	Carrying case.
Camera PH-324-A -----	Camera.
Case PH-371-A -----	Camera case.
Photographic Projection Printer EN-11 (1) -----	Printer or enlarger.
Exposure Meter PH-260-A -----	Light meter.
Timer PH-29 -----	Timer.
Board PH-317-A -----	Paper holder.
Graduate PH-11 -----	Graduate.
Rod PH-230 -----	Stirring rod.
Tank PH-322 -----	Developing tank.
Thermometer PH-28 -----	Thermometer.
Clip PH-165 -----	Film clip.
Cable Release PH-308 -----	Cable release.
Tray PH-158-A -----	Tray.

7. Packaging and Packing Data

Photographic Set ES-12 (1) is shipped completely assembled in the carrying case as follows:

a. *Domestic Shipment.*

- (1) All components of the equipment are placed or locked within their designated compartments of the carrying case (fig. 1).
- (2) The carrying case (fig. 3) is then locked and covered with the heavy olive drab cotton duck cover, which is secured to the lower edge of the case by snap fasteners. A heavy duty, olive drab cotton web strap is fastened around the cover and case.
- (3) The carrying case is placed within a close-fitting corrugated fiberboard carton and sealed with gummed tape (fig. 7).
- (4) The packaged case is placed within a nailed wooden shipping container which is bound with metal straps (fig. 7).

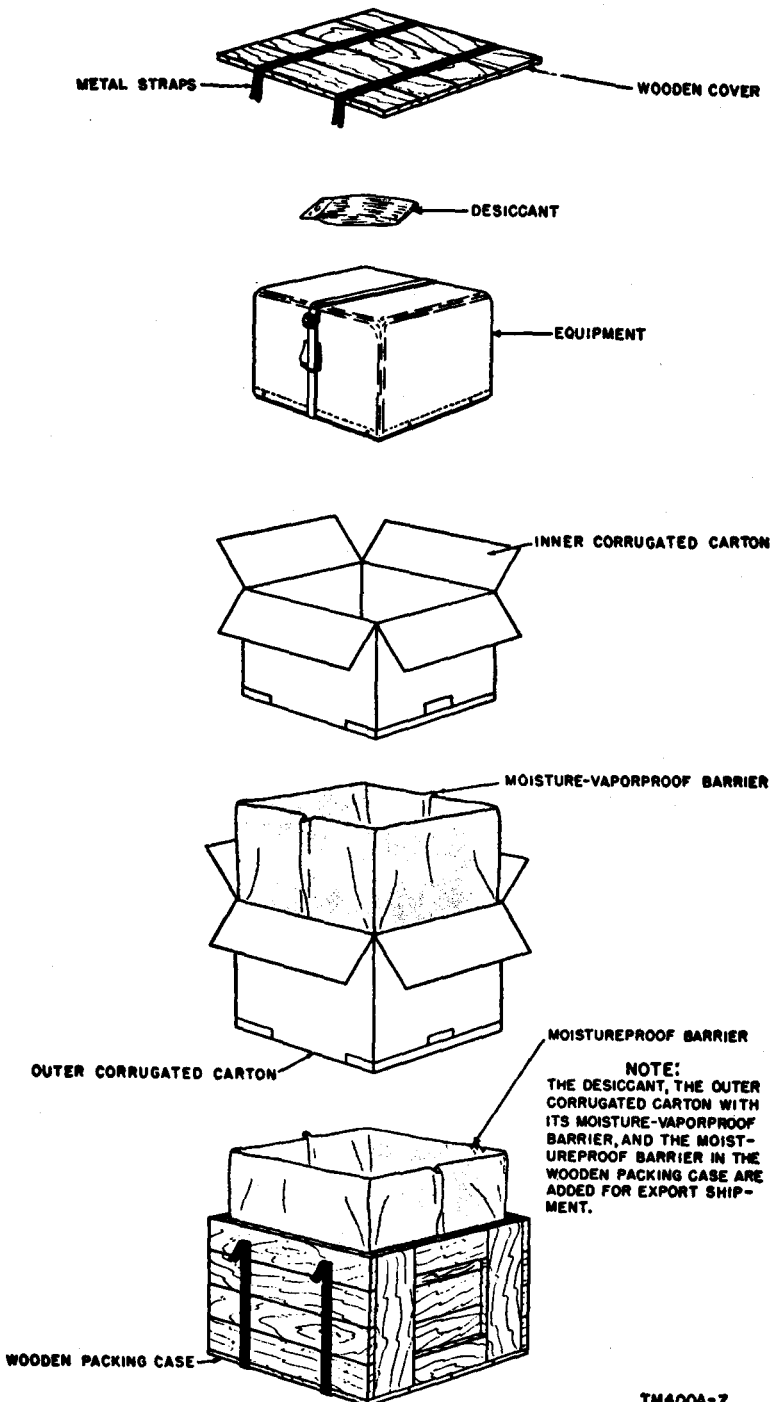

TM400A-7

Figure 7. Packaging and packing diagram.

- (5) The size of the wooden shipping container is approximately 27½ inches long by 19 inches wide by 25 inches high. The approximate weight of the shipping container is 127 pounds.
- b. Export Shipment.*
- (1) For export shipment the equipment is packaged as described in *a* (1) through (3) above except that a desiccant is placed within the corrugated fiberboard carton before closing and sealing.
 - (2) The packaged equipment is then placed within a second corrugated fiberboard carton which is lined with a moisture-vaporproof barrier. This carton is sealed with gummed tape (fig. 7).
 - (3) The packaged equipment is then placed in the nailed wooden shipping container which is lined with a moistureproof barrier (fig. 7).
 - (4) The lid of the wooden shipping container is nailed on and the container is further strengthened with metal straps (fig. 7).

CHAPTER 2

INSTALLATION

8. Uncrating, Unpacking, and Checking New Equipment

a. Uncrating. When uncrating the unit, proceed as follows:

- (1) Cut the metal straps with a suitable device, or twist them with pliers until the straps break (fig. 7).
- (2) Remove the nails with a nail puller. Prying may damage the equipment.
- (3) Carefully remove the top of the shipping container. Do not damage the wooden container because it may be reused for future repacking, shipment or storage. Avoid thrusting crowbars or other pointed tools into the interior of the shipping container.
- (4) Pull out the fiberboard carton from the shipping case and open the carton.
- (5) Pull out the second fiberboard carton from the first one and open it. Remove the desiccant.
- (6) Remove the carrying case containing Photographic Set ES-12 (1) (fig. 3) from the corrugated fiberboard carton and place it on a flat surface.

b. Unpacking (fig. 3). When unpacking the equipment from its carrying case proceed as follows:

- (1) Unbuckle and remove the strap.
- (2) Tuck the handles into the openings in the sides of the cover to prevent the carrying handles from catching as the cover is lifted.
- (3) Release the fasteners, which secure the bottom edges of the cover, and lift off the cover.
- (4) Release the trunk fasteners on front and top of the case and swing the two sides open.
- (5) Release the hasp to open the left-hand cabinet. To open the right-hand cabinet, swing the timer forward for access to the hasp.

c. Checking. When Photographic Set ES-12 (1) has been unpacked, check the equipment as follows:

- (1) Check against the packing slip to determine that all components have been supplied.

- (2) Inspect all parts for any damage that may have been caused by shipping or rough handling.
- (3) Be sure that this manual is understood thoroughly before attempting to operate or repair any components of the equipment.

Note. The procedure to be followed upon the receipt of used or reconditioned equipment is similar to that used for new equipment.

9. Locating the Equipment

a. Exterior Requirements. The site for the use of the processing unit is governed largely by the tactical situation, such as the need to keep the unit hidden, and by local conditions (the type of housing facilities available, tents, building, etc.). When setting up the unit, choose a location where a flat area is available. Be sure that drainage facilities are adequate.

b. Interior Requirements.

- (1) *General.* After locating the shelter in which the equipment is to be placed, make the necessary arrangements for blackout operation. Equip all windows with material that is opaque to prevent light from entering. Tents must be equipped with double flaps and buildings with double doors to serve as light traps. The ideal shelter is one which is dry and free from dust. Provide heating facilities when necessary. Be sure that ventilation is adequate.
- (2) *Space requirements.* Operating personnel must have sufficient space and table area to allow the work of processing prints to progress in the most convenient and efficient manner, with a minimum of lost motion. The minimum space required is 8 by 8 by 8 feet.
- (a) *Electrical requirements.* The printer, copy lights, and safe-light operate from a 105-to 120-volt ac or dc power supply. Be sure that all switches are accessible during operation. If the equipment cannot be located near the power source, use an extension power cable.
- (4) *Water requirement.* Large quantities of water (running, if possible) are needed for the washing of prints and negatives.

c. Equipment Location. Arrange the processing trays, tank, paper holder, and other equipment in the most convenient location for the operator. Develop a standard procedure for processing prints. Plain the various solutions in their designated positions at all times. This procedure prevents the use of the wrong solutions.

d. Connection (figs. 1 and 24).

- (1) Photographic Set ES-12 (1) is shipped completely assembled.

- (2) Place the equipment on a table or bench in a darkroom close to a 105- to 120-volt ac or dc power source. Connect the equipment to the power source as follows:
 - (a) Unwind enough of the power cable to reach the electrical outlet. (Use an extension power cable if necessary.) The power cable has a standard male plug on one end. The other end of the power cable terminate in the control unit mounted in the case (fig. 1).
 - (b) Check the safelight by snapping the SAFELIGHT switch on the control unit to on and off positions.
 - (c) Snap the accessory switch (ACC. RECEPTACLE) to on position to make sure that the copying lights are turned off at the sockets before making any enlargements. This will avoid fogging paper if the accessory switch is turned on accidentally in the dark.
 - (d) Check the enlarger lamp by connecting the male plug of the enlarger power cable to the female connector on the power cable extending from the control unit. Then snap the ENLARGER switch on the control unit to on and off positions.

CHAPTER 3

OPERATION

Section I. CONTROLS AND OPERATION UNDER USUAL CONDITIONS

Note. For Camera PH-324-A, refer to TM 11-2361A, for an explanation of the controls; for Exposure Meter PH-260-A, refer to TM 11-2356.

10. Table of Controls

The following tables list the controls used on the equipment. Do not attempt the operation of this equipment until the use of all operating controls is understood fully.

a. Photographic Equipment Carrying Case FM-W (1) (fig. 2).

Control	Location	Function
SAFELIGHT switch (fig. 27).	Control unit (right-hand side).	Turns safelight on or off.
Copy lights switch (fig. 27) (ACC RECEPTACLE).	Control unit (center) -----	Accessory switch for copy lamps.
ENLARGER switch (fig. 27).	Control unit (left-hand side).	Turns printer lamp on or off for exposure.
Lamp switches (fig. 16) --	Flexible arms of copy lights.	Turn copying lamps on or off at the bulbs.

b. Timer PH-29 (fig. 8).

Control	Location	Function
Minute hand setting knob.	Centered on rear of case --	Used to reset minute hand.
Second hand setting knob.	Top rear of case -----	Used to reset second hand.
Spring winding knob ----	Right rear of case -----	Used to wind timer.
START-STOP lever ----	Front of case -----	Starts and stops timer operation.
Speed regulator -----	Bottom rear of case -----	Serves as fast-slow adjustment.

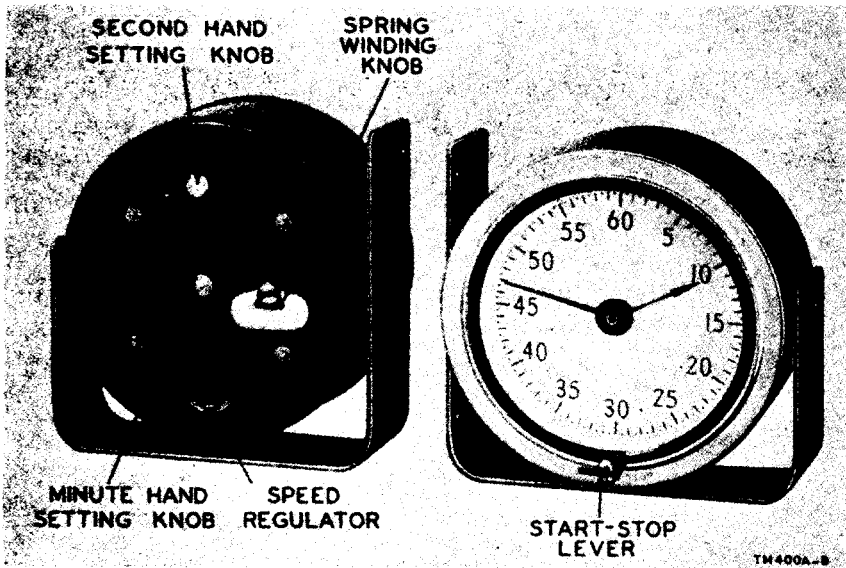

Figure 8. Timer PH-29, controls.

c. Photographic Projection Printer EN-11 (1).

Control	Location	Function
ENLARGER switch (fig. 27).	(Subpar. a above.)-----	
Focusing knob (figs. 5 and 25).	Right side of enlarger head.	Raises and lowers bellows for fine focusing adjustment.
Locking knob (fig. 25)---	Right side of post bracket.	Locks enlarging head at height desired for magnification.
Mounting screw knob (fig. 5).	Top of bracket-----	Fastens and secures lamp-house to bracket. Also holds camera for copying.
Control lever (fig. 5)---	Negative carrier-----	Holds negative firmly in position for printing.
Diaphragm ring (fig. 5)--	On lens-----	Regulates sharpness, light intensity, and depth of field of projected image.

d. Tank PH-322 (fig. 9).

Control	Location	Function
Locking knob.....	Centered on top of tank.	Unlocks cover from tank.
Magazine chamber knob.....	Top of smaller part of tank.	Locks film cassette in magazine chamber.
Round nosed index.....	Top of smaller part of tank.	Moves film from LOAD to DEVELOP.

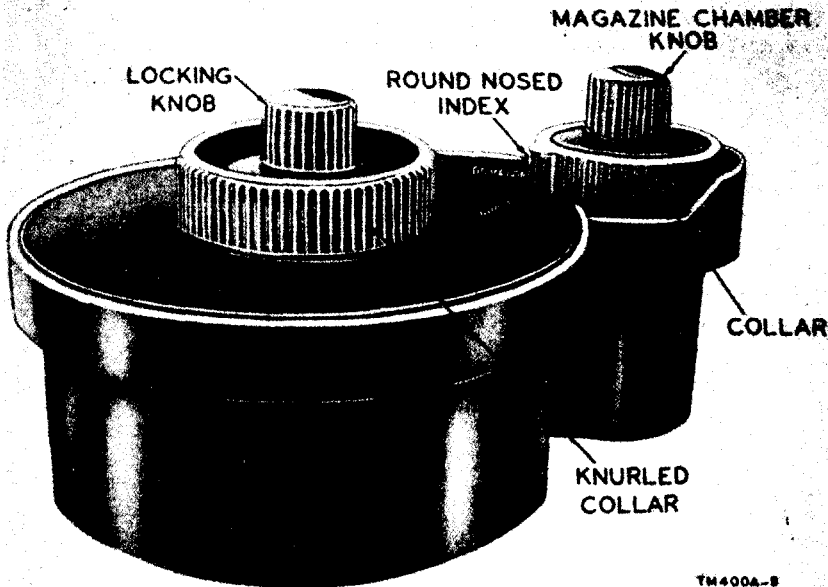

Figure 9. Tank PH-322, controls

11. Camera PH-324-A and Exposure Meter PH-260-A

The equipments must be clean and all parts must work freely in order to operate properly. The presence of foreign matter in the camera film compartment or in the exposure meter may scratch the film or jam the working parts. Equipment should be cleaned at regular intervals while in use. Refer to TM 11-2361A for complete instructions on Camera PH-324-A, and to TM 11-2356 for Exposure Meter PH-260-A.

12. General and Flash Photography

a. Attaching Lens Hood and Filter (figs. 4 and 10).

- (1) Press the adapter ring over the lens mount of the camera so that the spring fingers will grip the lens mount firmly. Attach the lens hood to shade the lens from direct sunlight

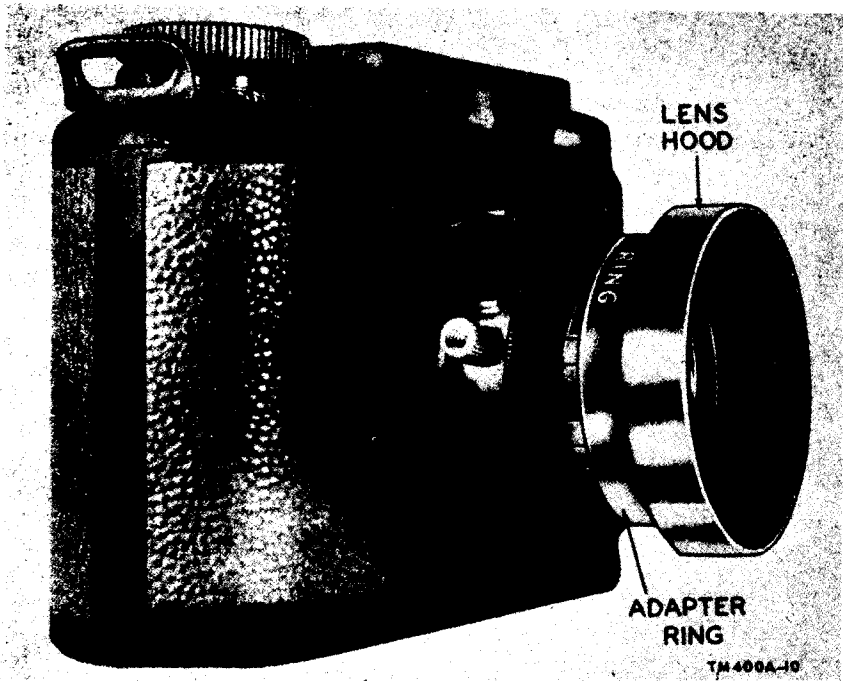

Figure 10. Lens hood attached to Camera PH-324-A.

by screwing it into the adapter ring. No change in exposure is necessary when the lens hood is used.

- (2) To use the K2 filter, unscrew the lens hood from the adapter ring, place the filter in the recess of the lens hood, and screw the lens hood back into the adapter.

b. Flash Synchronizer (figs. 11, 12, and 13). To attach and adjust the flash synchronizer to Camera PH-324-A proceed as follows:

- (1) Remove the flash synchronizer from its storage compartment in the carrying case. Remove the bottom cover plate (11, fig. 11) of the reflector battery case (1) by unscrewing the holding screw (12). Place two 1½-volt C size batteries in the battery case so that one is head up and the other head down; then replace the cover plate.
- (2) Attach the extension bracket (3) to the bottom of the reflector battery case (1) with the small screw (4).
- (3) Remove Case PH-371-A from Camera PH-324-A by unscrewing the thumbscrew located in the bottom of the case. Then attach the other end of the extension bracket (3) to the tripod socket of the camera with the large tripod screw (5). The reflector battery case (1) can be attached to either the right or left side of the camera. For convenience in

operation, place the reflector as shown in figure 13. The reflector must face the same direction as the front of the camera. Be sure that no film is in the camera when making the adjustments.

- (4) Loosen the synchronizer head (6, fig. 11) halfway on its threads and screw it firmly, but not too forcibly (clockwise) into the cable release socket of the camera.
- (5) Plug the synchronizer connector (7) of the synchronizer cord (2) into the terminal outlets on the right side of the reflector battery case (1).

Note. While adjusting the synchronizer, it may be necessary to remove the leads from the reflector battery case to untwist the synchronizer cord. After doing so, replace the leads and continue with the adjustment.

- (6) Set the camera shutter at 1/25th. Press down very slowly on the camera shutter release lever (fig. 13) and watch for the

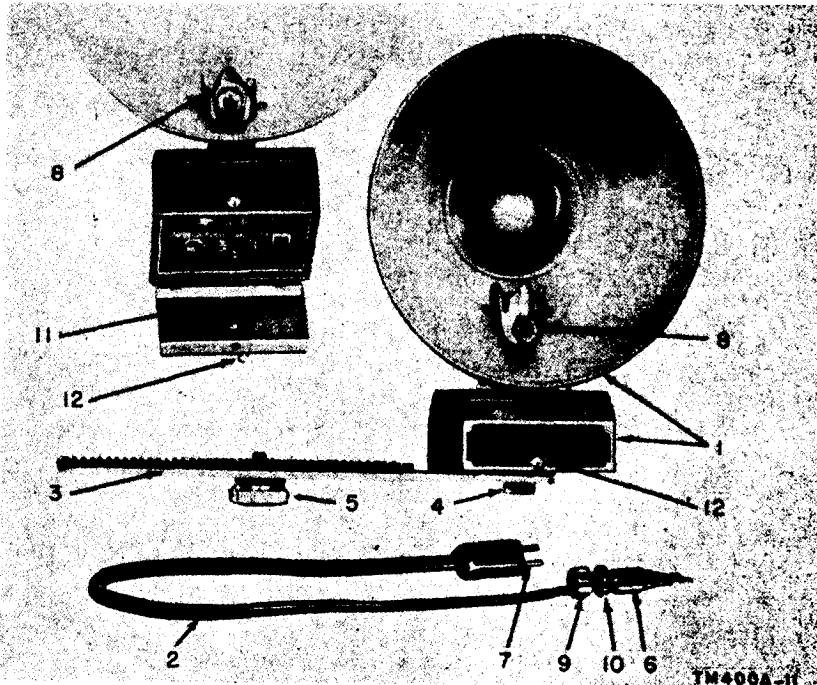

- | | |
|--------------------------|--------------------------|
| 1 Reflector battery case | 7 Synchronizer connector |
| 2 Synchronizer cord | 8 Test lamp |
| 3 Extension bracket | 9 Adjustment knob |
| 4 Small screw | 10 Lock ring |
| 5 Large tripod screw | 11 Bottom cover plate |
| 6 Synchronizer head | 12 Holding screw |

Figure 11. Synchronizer assembly.

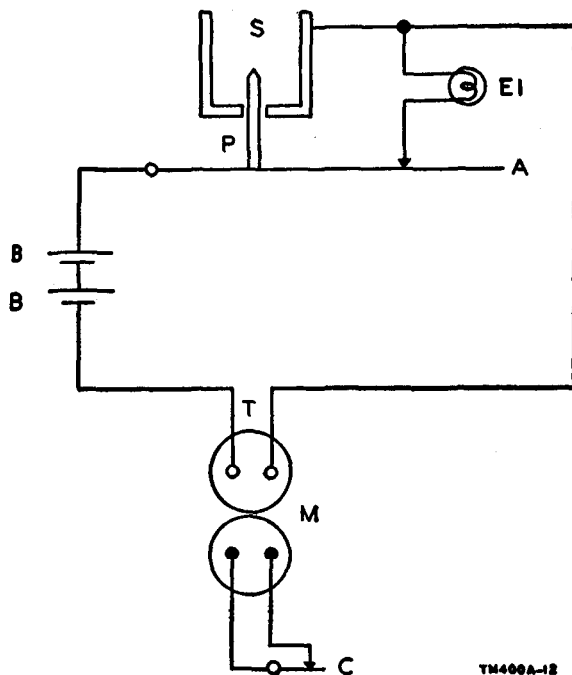

TM400A-12

- | | |
|--------------------------|---|
| P Socket pin | A Automatic switch for safety lamp |
| S Socket body | T Terminal outlets |
| B C size cell (2) | M Synchronizer leads |
| E1 Test lamp | C Synchronizer switch |

Figure 12. Flash synchronizer, schematic diagram.

test lamp (8, fig. 11) to light. The lamp should light only when the shutter clicks.

- (7) If the test lamp fails to light, turn the lock ring (10, fig. 11) upwards (counterclockwise) and release the shutter again. If the test lamp lights before the shutter clicks turn the lock ring (10) downwards (clockwise) and again release the shutter slowly. Repeat these adjustment trials until the test lamp (8) lights at exactly the same time that the camera shutter clicks.
- (8) When the test lamp (8) lights at exactly the same instant that the shutter clicks, lock the adjustment permanently by turning the lock ring (10) down (in a clockwise direction) as tightly as possible. Once this adjustment is made and locked, the synchronizer head (6) will remain adjusted to the camera no matter how often it is removed and reattached.
- (9) Load Camera PH-324-A with film in accordance with instructions contained in TM 11-2361A. When loading the camera, it is more convenient to detach the flash synchronizer and to reattach it after the film is inserted.

- (10) Insert a midget bayonet-base photoflash lamp into the socket of the reflector. The lamp slides straight in and is held firmly in place in the socket. Do not remove the test lamp (8) ; it acts as a safety device which guards against flash lamps flashing accidentally.

Caution: Never insert a flash lamp if the synchronizer head (6) is connected to the camera and the test lamp (8) is lighted, This is a warning signal that the synchronizer head (6) is incorrectly adjusted or not properly attached to the camera.

c. Focusing camera (fig. 13).

- (1) To determine the lens stop opening, and for proper exposures, consult the flash exposure table in *d* below.
- (2) When the distance and lens opening have been determined, set the *f*/opening of Camera PH-324-A by moving the pointer under the shutter and lens assembly. Hold the camera so that the index finger of the left hand rests naturally on the focus knob and the index finger of the right hand rests on the knob of the shutter release. Keep fingers away from the lens and other glass.
- (3) To focus, place one eye against the rangefinder eyepiece and focus the camera on the subject. Adjust the focus by moving the focus knob with the index finger of the left hand. A split image of the subject will appear in the eyepiece of the rangefinder when the camera is not focused. As the focus knob is moved, the bottom part of the image will appear to move sideways. Select an approximately straight and vertical line on the subject and move the focus knob until a single image appears with the selected line unbroken.
- (4) When this condition is obtained, the camera is focused properly, and the distance between the camera and the subject should not be changed until after the exposure is taken.
- (5) Place the eye against the viewfinder eyepiece and frame the subject in the viewfinder.
- (6) Hold the camera firmly (press against the nose and the cheek) and slowly press the shutter release as far as it will go, using the index finger of the right hand. The complete action of the shutter will be indicated by two clicks: the first is due to the plunger rod; the second to the shutter action.
- (7) Remove the finger from the shutter release. The plunger should prevent complete return of the shutter release to an operating position, and the red dot on the end of the plunger should be visible.

- (8) After making the first flash exposure, turn the film to the next number in the usual manner.
- (9) To replace the flash bulb for the next picture, press the lamp ejector at the back of the reflector to eject the burned out bulb.

Caution: Do not flash the bulbs in an explosive atmosphere. Be sure that the camera shutter is not open (for example, set on T) before inserting the flash lamp in the reflector; the lamp may flash and a serious burn may result.



Figure 13. Camera PH-324-A in operating position with synchronizer attached.

d. Photoflash Exposure Table.

Film type	Shutter speed	Photoflash lamp	Distance in feet from flash to subject				
			6'	8'	10'	15'	20'
Kodak, Plus X.....	Up to 1/50.....	SM.....	f/16	f-stop			4
		No. 5 or 25.....	f/32	11	8	5.6	4
Dupont Superior 2.....	1/200.....	No. 5 or 25.....	f/22	22	16	11	8
		No. 5 or 25.....	f/16	16	11	8	5.6
Kodak Super XX.....	Up to 1/50.....	SM.....	f/16	11	8	5.6	4
		No. 5 or 25.....	f/22	16	11	8	5.6
Ansco Ultra Speed Pan.....	1/100.....	No. 5 or 25.....	---	f/32	22	16	11
		No. 5 or 25.....	f/32	22	16	11	8
	1/200.....	No. 5 or 25.....	f/22	16	11	8	5.6

Note. All exposure data is based on the assumption that the film to be used is in prime condition. Prior to its use under these conditions, the operator should consult available data regarding the change of sensitivity of film at extreme temperatures and after long storage.

e. *Camera Mounting Clamp* (fig. 14).

- (1) Camera PH-324-A should be placed on a stationary support when time and bulb exposures are made. The camera may be set on a flat surface or attached to a convenient object by means of the camera mounting clamp furnished with the equipment.
- (2) To attach the clamp to the camera, tighten the locking screw on the clamp so that the ball swivel will not turn. Screw the ball swivel screw into the tripod socket of the camera.
- (3) Pull the jaws of the clamp open, using the finger grips, and place the jaws over a fence rail, tree branch, or other object. Press the points firmly into the surface.
- (4) Loosen the locking screw, position the camera, and tighten the screw again.
- (5) When the clamp is attached in a horizontal position, place the inside or swinging jaw on top.

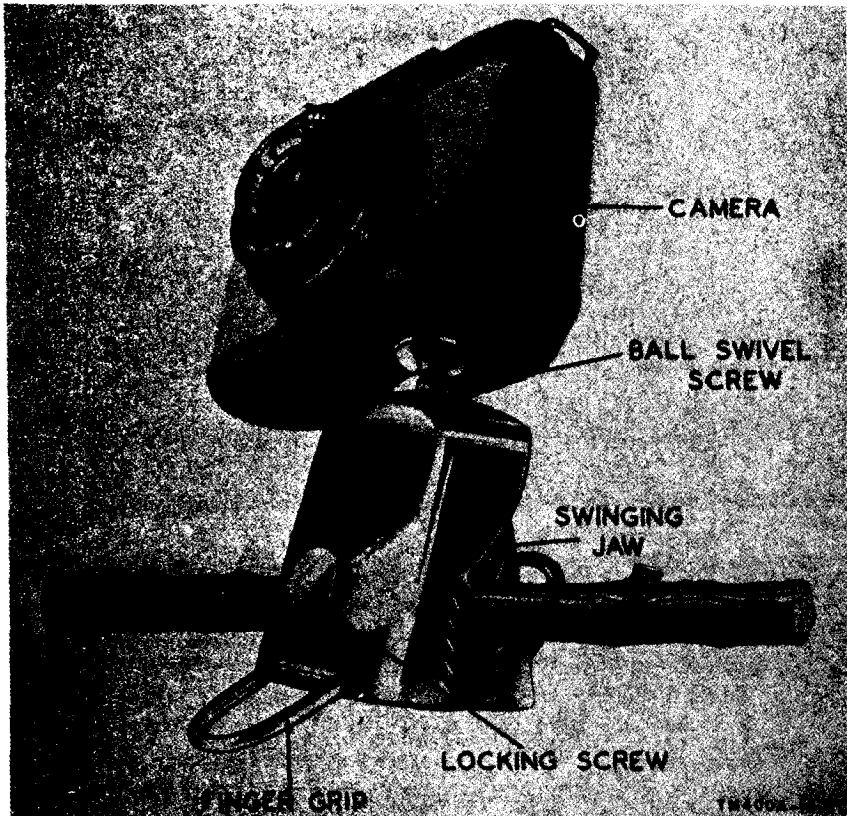

Figure 14. *Camera mounting clamp, with Camera PH-324-A attached.*

- (6) Do not attach the clamp to iron or stone. This will dull the teeth. Avoid using any surface which the clamp cannot grip firmly. Do not oil the ball.

Warning: Do not allow fingers to get caught between the jaws.

13. Copying

a. General. Copying by photography provides accurate reproductions of photographic prints, drawings, sketches, manuscripts, typed and printed matter, and many similar subjects. Photographic copies of these subjects can be made with Camera PH-324-A mounted on the enlarger bracket and fitted with a supplementary lens (par. 4e (5)).

b. Film Choice. In copy or close-up work, it is usually necessary to reproduce detail as fine as possible. This requires the use of a fine-grain film; the finer the inherent grain, the greater the ability of the film to reproduce detail. For this purpose, the finer grain 35-mm films may be divided into two types-

- (1) Medium-speed, fine-grain films, such as Eastman Panatomic X, Dupont Superior No. 1, and Ansco Finopan. These films may be used for general work because they have good latitude and are capable of reproducing delicate graduations.
- (2) Slow-speed, extremely fine-grain films, such as Eastman Micro file, Dupont Microcopy, and Ansco Minipan. These films may be used when copying maps, charts, handwritten or typed documents, printed matter, and line drawings because of their ability to resolve fine detail. Where only black and white charts are to be copied, positive film may be used. This film is ordinarily used to make film positive from 35-mm negative and can be used in copy work where no colored material is to be copied.

c. Setting Up for Copying (fig. 15).

- (1) Load Camera PH-324-A with the proper negative film for the subject. The lens should be stopped down to about $f/16$ to provide a depth-of-field leeway for correcting slight inaccuracies of focus.
- (2) To obtain an image of sufficient size, use a 1-plus or a 2-plus portrait lens on the camera (fig. 4).
- (3) Place the chosen portrait lens with its convex surface and the engraved arrow on the rim, facing downward, away from the camera lens, into the recess of the lens hood. Screw the adapter ring onto the lens hood.
- (4) When the K2 filter (fig. 4) is used in addition to the portrait lens, use the retaining ring to hold the portrait lens in the adapter ring. The filter then can be mounted in the front of the retaining ring by use of the lens hood. Always place

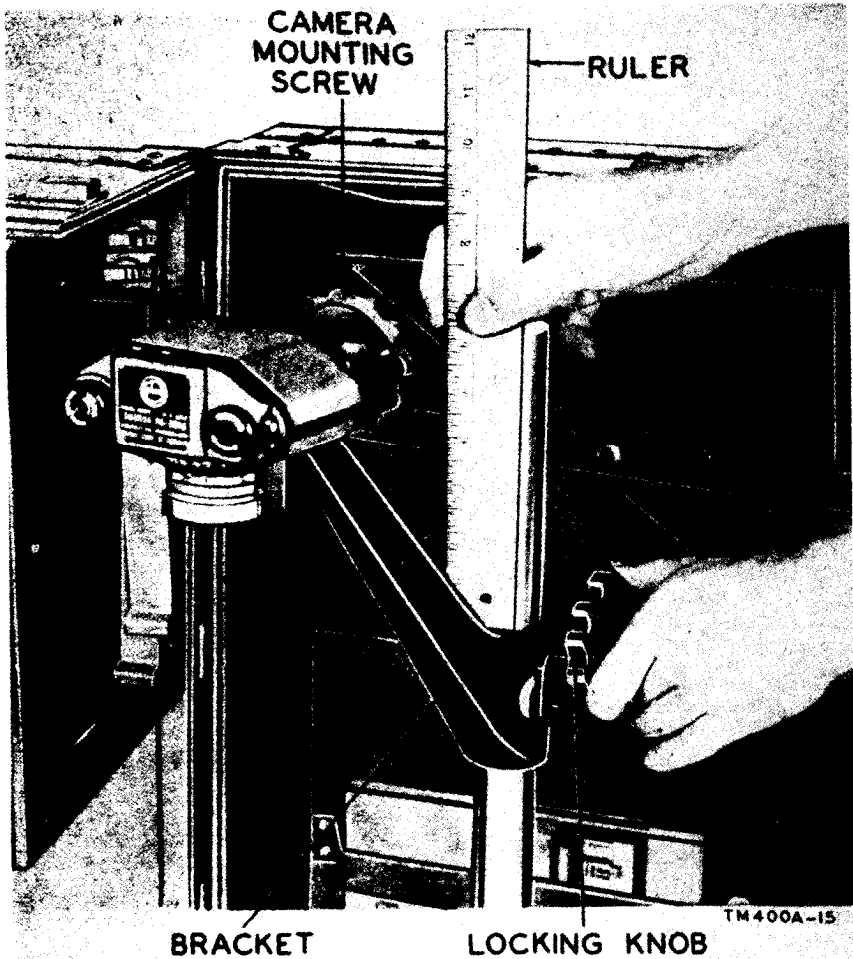

Figure 15. Measuring to set distance from lens to subject.

the portrait lens directly in front of the camera lens. Use the K2 filter when copying yellowed documents or papers written in light blue ink to increase the contrast. Increase the calculated exposure by 1.5 when using the filter with panchromatic film and by 2 when using the filter with orthochromatic film.

- (5) Slip the flange of the adapter ring over the rim of the camera lens mount; press it on carefully until it bears evenly on the camera lens mount and is square with the camera axis. If necessary, bend the fingers (on the adapter ring) slightly in or out to grip the lens mount firmly.
- (6) To remove tile printer head, unscrew the mounting screw at the back of the printer head. To mount the camera to the

bracket, turn the mounting screw into the camera tripod socket.

- (7) Tighten the mounting screw to hold the camera firmly; make sure that the camera has not moved. The camera should now be in alignment with the field markings on the baseboard.
- (8) Loosen the locking knob on the column to raise or lower the bracket.

d. Focusing Adjustments.

- (1) Focusing and composing can be accomplished most efficiently if the original material is laid on the baseboard and correctly centered within the proper area size of the four camera settings shown on the printer baseboard (fig. 16), with the camera pointing down toward it. A wider range of subject distances and camera settings are given in table I. This table may be used for copying with portrait lenses plus 1 and plus 2. The subject distances apply only to Camera PH-324-A and must be measured accurately between the subject and the supplementary lens. Exposures should always be made at a small aperture when a supplementary lens is used.
- (2) Center on the baseboard the original material to be copied. Loosen the locking knob on the column bracket and move the camera up or down to adjust the distance desired from the subject to the supplementary lens. The 12-inch ruler (fig. 15) is useful for measuring the lens-to-subject distance,

Notc. When the subject is (for example) a book or bound manuscript, subtract the thickness of the subject from the value in the fourth column of table 1 in order to keep the lens-to-subject distance correct.

Table 1. Field size and subject distance of camera PH-324-AA (with 44-mm lens) mounted on the printer column and using portrait lens for copying

Portrait lens	Approximate field sizes (in.)*	Camera lens setting (ft)	Lens-to-subject distance (in.)	Length of post above bracket (in.)
Plus 1 lens-----	9 ² / ₃₂ x 14 ³ / ₆₄	3	18 ² / ₂	0
	8 ³ / ₁₆ x 13 ¹ / ₁₆	2.6	17	6 ³ / ₁₆
Plus 2 lens-----	7 ⁷ / ₁₆ x 11 ⁵ / ₁₆	2	14 ² / ₂	8 ³ / ₁₆
	9 ¹ / ₁₆ x 14 ² / ₃₂	24	18 ¹ / ₂	0
	9 ⁹ / ₁₆ x 13 ² / ₃₂	12	17 ⁷ / ₁₆	5 ⁷ / ₁₆
	8 ⁴ / ₆₄ x 13	18	16 ⁷ / ₁₆	6 ⁷ / ₁₆
	8 ³ / ₁₆ x 12 ¹ / ₆₄	6	15 ¹ / ₂	7 ³ / ₄
	7 ¹ / ₁₆ x 11 ³ / ₆₄	5	14 ¹ / ₁₆	8 ³ / ₁₆
	7 ⁷ / ₁₆ x 10 ² / ₃₂	4	13 ² / ₃₂	9 ³ / ₁₆
	6 ³ / ₆₄ x 9 ⁵ / ₆₄	3	12 ⁴ / ₆₄	10 ¹ / ₂
	6 ¹ / ₁₆ x 9 ³ / ₃₂	2.6	11 ² / ₃₂	11 ³ / ₄
	5 ⁷ / ₁₆ x 8 ⁵ / ₃₂	2	10 ⁵ / ₆₄	12 ³ / ₈

*The field sizes are based on the size of the picture area actually used.

e. *Illumination* (fig. 16)

- (1) Proper light distribution and control of reflections are important when illuminating the original material for copying. As a light source, the photoenlarger lamps furnished with the equipment are suitable for black and white copying. Light distribution is much more critical in copying than in other photographic work. When setting up for copying, place the lamps so that all the corners of the original material are equally lighted.
- (2) Screw the two photoenlarger lamps into the copy light sockets of the flexible arms mounted on the baseboard.
- (3) Plug the copy lights' power cable into the outlet on the underside of the control unit box (fig. 24) and turn on the accessory switch.
- (4) Turn on the lamps (knurled switch knob on each lamp) and adjust the reflectors to give uniform lighting over the part of the field area covered by the reflectors. The lamps should be placed at an angle of 45° to the copy to give a maximum of light on the subject. Do not permit the lights to come between the copy and the camera. To test the lighting, hold a card on its edge in the center of the copy. When shadows are equal on both sides of the card, the lighting is even. Be sure that there are no reflections that will throw glare into the lens and ruin definition. Light from the lamps is reflected into the lens by the original material, especially if it has a creased or curved surface. Try to eliminate any bright reflections by flattening the surface of the subject or by adjusting the lamps.
- (5) Adjust the lights to give even illumination in the film plane in the camera. View the original material, if possible, from a point close to the lens to detect any reflections that might reach the lens.

f. *Determining Correct Exposure.*

- (1) Exposure Meter PH-260-A should be used for determining exposures for copying. The most consistently reliable results are obtained by measuring the illumination on the original material; to do this, hold the meter so that it receives reflected light only from that portion of the subject which is to be included in the photograph. Do not cast a shadow upon an object when a light-value reading of that object is being taken.

Note. For further information on the correct methods of holding the meter, refer to TM 11-2356.

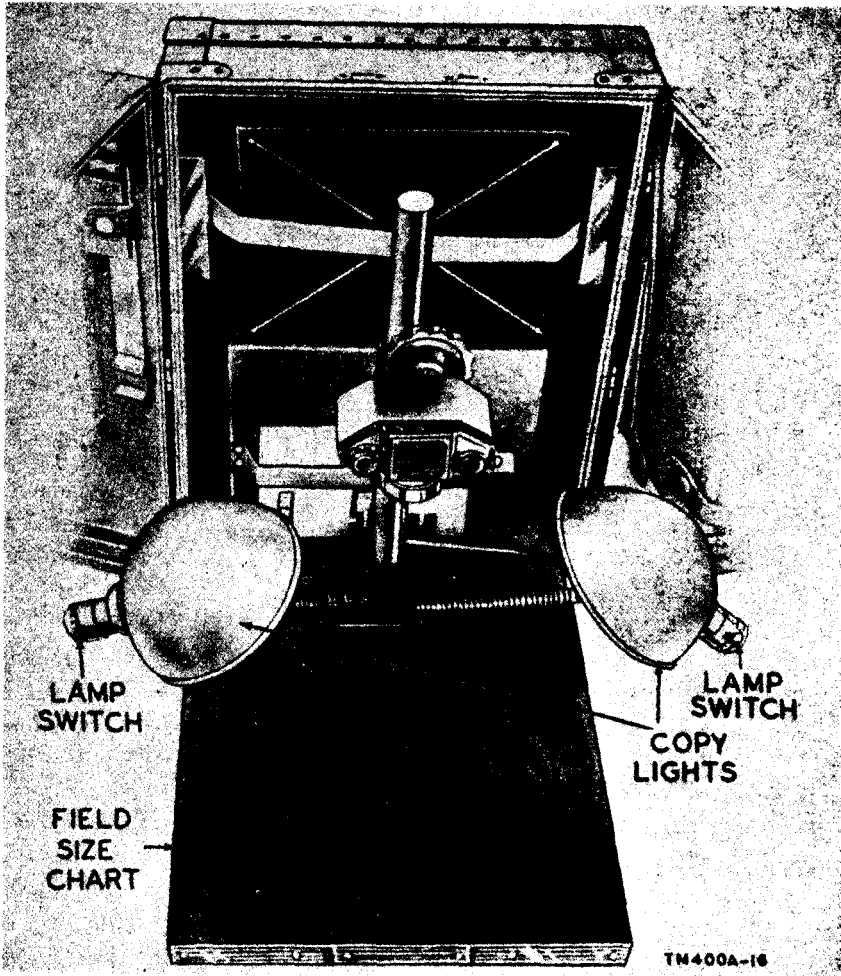

Figure 16. Camera PH-324-A. and copy lights set for copying.

- (2) When setting the calculator dial of Exposure Meter PH-260-A, use the appropriate emulsion speed rating of the film as determined either from the manufacturer's rating or from the continuous tone and line copying data in table II.

Table 11. Continuous-tone and line copying

Subject type	35-mm film	ASA speed exposure indexes		Developer	Recommended development in minutes at 68° F. (20° C.)		Safe light factor
		Day	Tungsten		Continuous agitation (tray)	Intermittent agitation (tank)	
General work.	Super XX	100	80	Microdol or D-76	16	20	Total darkness.
	and Plus X	50	40	Microdol or D-76	13	16	Total darkness.
Continuous-tone copy.	Ultra Speed Pan	100	80	Microdol or Ansco 17	9-13	12-17	Total darkness.
	Superior 2	50	32	Microdol or Dupont 5-D	19	25	Total darkness.
	Supreme	50	32	Microdol or Ansco 17	6- 8	9-12	Total darkness.
	Fine-grain positive	1.2	.3	Universal M-Q D-76	3	4	Light red filter (1-A).
Line copy	Panatomic X	25	20	Microdol or D-76	11-12	14-15	Total darkness.
	Microfile		3	Universal M-Q or D-11	2½- 4	5-11	Total darkness.
	Fine grain	1.2	.3	Universal M-Q or D-11	7	9	Light red filter (1-A).

- (3) Make the exposure at the smallest aperture practicable, preferably $f/16$ or $f/11$. The two lamps used in the copy lights when operated at normal voltage require an exposure of approximately $1/25$ second at $f/8$ with microfilm. If the reading indicates a longer exposure, readjust the copy lights to increase the intensity of light on the copy. There is very little permissible latitude in the exposure because of the high contrast of the film. One atop underexposure will produce an excessively thin negative, while one stop overexposure will cause filling in of letters and fine lines.
- (4) Copy negatives of continuous-tone originals should be exposed and developed so that most of the detail of the shadow areas is retained. The negative should have greater overall density than an original negative of the subject. The contrast should be normal.
- (5) Good copy negatives of line originals are characterized by dense backgrounds and clear lines. Fine lines should be clear and easily distinguishable by reflected light from a sheet of white paper and not obscured, or *closed up*. Prints from copy negatives of black, coarse line originals should be made on a very high contrast paper.
- (6) Drawings and typed or printed matter can be copied with any of the materials recommended for line copying in table II. When making copies of drawings, letters, or other originals that are printed on one side only, the material should be backed with white cardboard or a blotter in order to increase the effective whiteness of the paper and give greater contrast. If the material to be copied is printed on both sides, it should be backed up with black paper or a black card to keep the lines or lettering on the back from showing through.
- (7) Before starting any extensive copying, make and develop a series of test exposures of a typical subject, as a check on exposure and focus settings. Refer to paragraph 15j for developing a short length of film. When there are only a few subjects, make three negatives of each-one at the calculated setting, one at the next larger aperture, and one at the next smaller aperture. One of these three should be usable.

g. Microfilm Processing.

- (1) Refer to paragraph 15 for information on mixing the necessary solutions.
- (2) Lend the film into processing Tank PH-322 as described in paragraph 15b.

- (3) Pour the developer solution into the tank, and agitate the film intermittently for 5 minutes at 68° F. (20° C.). If it is necessary to work at some other temperature, adjust the time accordingly. The time should be approximately 4 minutes at 75° F. (23.9° C.) or 6½ minutes at 60° F. (15.6° C.).
- (4) Rinse, fix, and wash as described in paragraphs 15e, f, and g.
- (5) After washing, remove the film from the developing reel to a bucket or tray of clean water, and swab both surfaces of the film under water with the viscose sponge to remove any dirt or scum. Wash out the sponge and squeeze out the excess water. Hang the film to dry, using the film clips provided, and swab the film with the viscose sponge to remove all water drops (fig. 23).
- (6) Enlarge the line negatives on No. 3 contrast paper.

h. High Speed Panchromatic Processing. Repeat the procedure in *g* above. When copy negatives of continuous-tone material are being processed, increase the processing time by 25 percent. Good results also can be obtained by using Universal M-Q Developer. Develop the negatives for approximately 6 minutes at 68° F. (20° C.).

14. Enlarging

a. Preliminary Procedures. Before operating the printer, proceed as follows:

- (1) Refer to paragraph 15 for information on mixing the necessary solutions.
- (2) Pour the developer solution into one of the 8- by 10-inch trays to a depth of approximately 1 inch (approximately 48 ounces).
- (3) Fill another tray with a fixer solution to a similar depth. Fill the remaining tray with water.
- (4) Arrange the three trays, containing developer, water, and fixer, in a convenient position. The fixer and water trays should be well filled to insure proper immersion of large numbers of prints.
- (5) Connect the printer cable to the power source as shown in figure 24.

b. Loading Negative Carrier (fig. 17).

- (1) Hold the carrier so that the curve in the film holder faces upward.
- (2) Raise the top plate and place the film in the carrier with the emulsion side down so that it projects over the aperture of the bottom plate.
- (3) Close the negative carrier and place it in the printer.

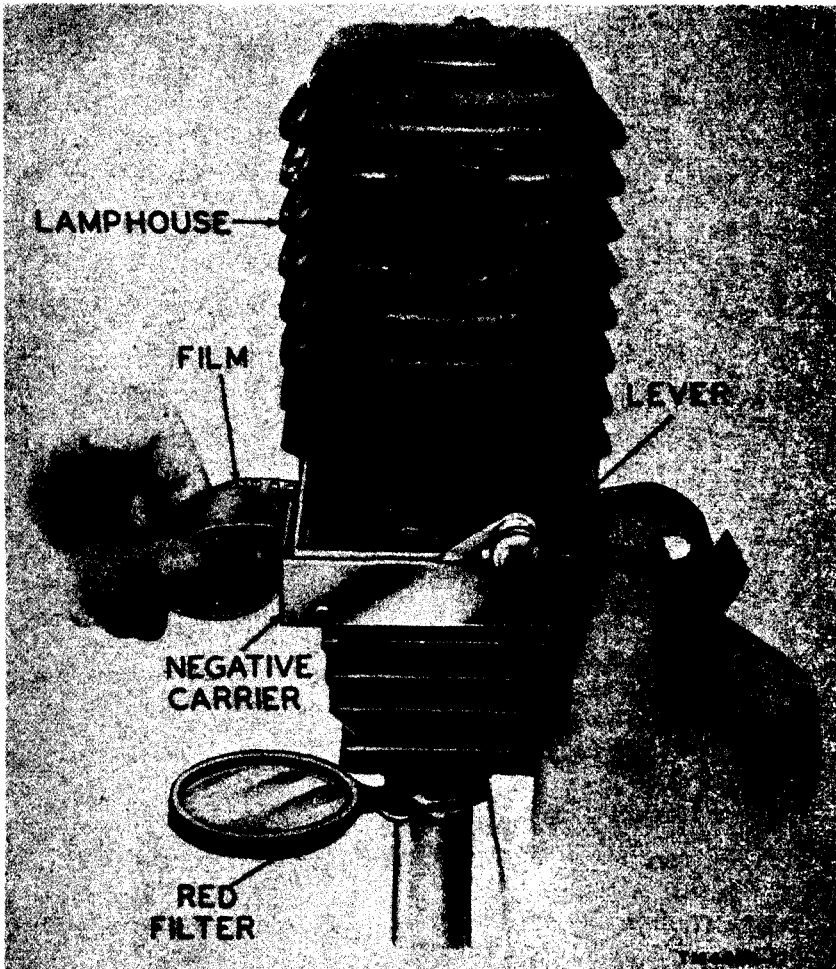

Figure 17. Inserting negative carrier.

- (4) To adjust or advance the film, swing the front lever of the negative carrier to the right, thus releasing the pressure, and slide the film strip through the carrier until the frame to be enlarged is centered in the aperture; then swing the lever to the left to hold the film in position. The remaining rolled film should rest on the film holders.

Note. The carrier also may be used when a single cut frame of 35-mm film is to be enlarged.

c. Board PH-317-A (fig. 18).

- (1) Raise the hinged frame by depressing the springs.
- (2) Place a sheet of photographic enlarging paper or blotter on the base of the board to aid in focusing.

- (3) Lower the hinged frame.
- (4) Release the masking arms by turning the locking knobs counterclockwise.
- (5) Set the masking arms so that the visible area of paper is equal to the desired size of the enlargement to be made.
- (6) Lock the masking arms in position by turning the locking knobs clockwise.

d. Focusing (fig. 5).

- (1) Darken the room except for the safelight.
- (2) Remove the lens cap.
- (3) Move the ENLARGER switch on the control unit (figs. 24 and 27) to on.
- (4) Load the paper holder (*c* above) with a sheet of plain white paper or a blotter and set the paper board under the projected image.
- (5) Loosen the bracket locking knob and raise or lower the enlarger head on the column until the size of the projected image is approximately the size of the desired print. The greater the distance between the paper and the negative, the greater the size of the enlargement will be.
- (6) Tighten the locking knob screw by turning it clockwise.
- (7) With the projection lens set at $f/4.5$, raise or lower the bellows by turning the focusing knob (fig. 5) until the en-

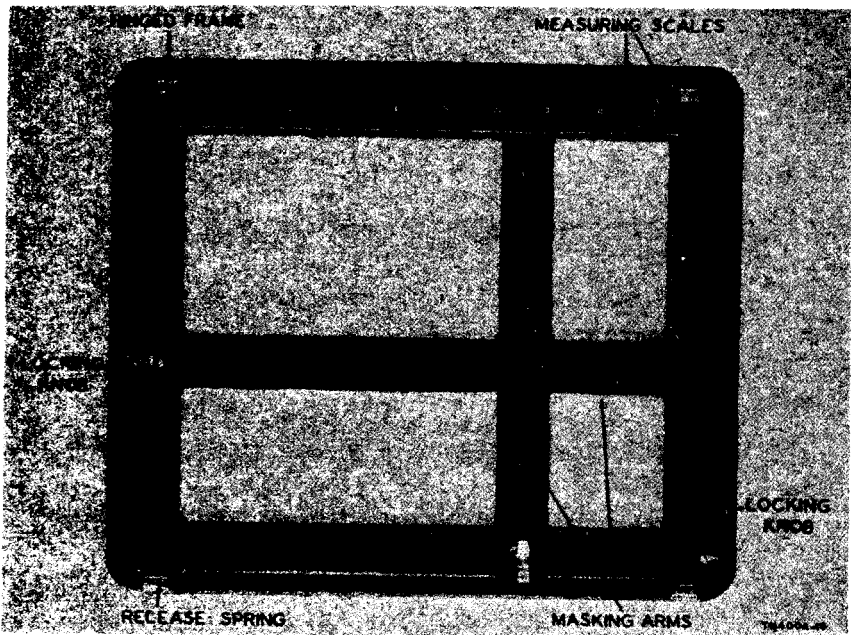

Figure 18. Board PH-317-A.

larged image is in sharp focus. Adjust the f /stop opening of the projection lens until the desired illumination of the enlarged image is obtained.

(8) Move the ENLARGER switch down to the off position.

e. Test Prints.

- (1) Before making the first full-sized picture, make one or more test exposures to determine the correct exposure. Select the grade of paper suitable for the contrast of the negative.
- (2) Cut a strip from this paper about 2 inches wide and long enough to place the edges under the adjustable masking arms of the paper holder. Place the strip across the center of the paper holder and under the paper guides with the emulsion or sensitive side facing the printer.
- (3) Cover all but one-fourth of the strip with a piece of cardboard and switch on the printer lamp for 32 seconds; uncover another fourth of the strip and expose for 16 seconds; uncover the third quarter and expose for 8 seconds; and finally uncover the last quarter for another 8 seconds.
- (4) The entire strip has had four different exposures; the first quarter, a total exposure of 64 seconds; the second quarter, 32 seconds; the third quarter, 16 seconds; and the fourth and last quarter, 8 seconds. Develop the test strip for the time recommended with the developer being used: rinse, and then fix for 1 or 2 minutes in the hypo tray.
- (5) Examine the print, preferably under a white light, and select the exposure time indicated by the most satisfactory section of the test strip. If the test exposures are all very much overexposed or underexposed, make another test strip; use the first strip as a guide to the time of exposures. If the image comes up too rapidly and the overall tone is too dark, it has been overexposed; if the image comes up slowly and the overall tone is too light, it has been underexposed.

f. Operation of the Printer.

- (1) After the correct exposure has been determined, reload the paper holder with a sheet of photographic enlarging paper.

Note. Waterproof base paper is the type of enlarging paper referred to in this procedure.

- (2) Turn the red filter until it is directly below the projection lens (fig. 5).
- (3) Move the ENLARGER switch up to the on position.
- (4) Make a final check to be sure that the enlarger paper is in the proper position.

- (5) Move the ENLARGER switch down to the off position, and move the filter away from the projection lens.
- (6) Set the hands of Timer PH-29 (fig. 8) to O (60 on timer), and push the START-STOP lever to *START*. Move the ENLARGER switch up to the on position to make the exposure. The required exposure time depends on the f/stop of the projection lens, the type of enlarging paper used, the density of the negative, the desired print density, and the degree of magnification.
- (7) Move the ENLARGER switch down to the off position after sufficient exposure time has been allowed.
- (8) Unload the exposed paper from the paper holder and insert it, quickly and smoothly, into the developer tray with the emulsion side up. This will assure an even starting of the development and prevent air from being trapped under the paper, which may cause spots.
- (9) After the desired number of prints have been made, leave the ENLARGER switch down in the off position. Remove the negative carrier from the printer, and replace the lens cap.

g. Developing Prints (Water Resistant Base Photographic Paper).

- (1) Maintain all solutions as close to 68° F. (20° C.) as possible. Develop the exposed paper for the normal length of time (1½ minutes for bromochloride papers and 2 minutes for bromide papers).
- (2) Rinse the prints for a few seconds.
- (3) Fix the prints for approximately 2 minutes, depending on the strength of the fixing solution.
- (4) Wash the prints thoroughly for 5 minutes in a good flow of water, or if a flow is not possible, wash them in at least five complete changes of water. Allow 2 or 3 minutes of washing time for each change of water. After washing, place the prints on a clean, inclined surface and allow them to drain thoroughly. To avoid soiling the prints, the drainboard should be made of an easily cleaned, noncorroding material, such as glass or stainless steel. After draining, swab off the prints with a clean cloth, viscose sponge, cotton, or a large squeegee, before they are put between blotters or laid out face up to dry.

Note. When working with regular enlarging paper without a waterproof base, allow the paper to remain in the fixing solution for at least 10 minutes and wash in a good flow of water for 1 hour. Blot off the excess moisture and dry face down on blotters or a clean white cloth.

- (5) Avoid contaminating the blotters with poorly washed prints. By removing the excess surface water, this treatment will help prevent irregularity in print surface and edges, curl, or other trouble.

15. Processing Film

For general information on the taking of pictures and the processing of photographic negatives, refer to TM 11-401, Elements of Signal Photography.

a. Mixing Chemicals.

- (1) Make the standard solutions used in developing and fixing by dissolving recommended prepared chemicals in water. Dissolve the contents of one package (2 units) of Microdol Developer, or the equivalent, in water (according to the instructions on the package) to make 16 ounces of developer solution.
- (2) Prepare 16 ounces of fixer solution by dissolving the chemical in the ratio of 1 ounce (30 grains) of chemical to 5 ounces (approximately 150 cc) of water. Be sure to follow the mixing instructions on the package when preparing these solutions.

b. Loading Processing Tank PH-322 (fig. 19).

- (1) The film leader must have the conventional cutout and must extend from the film magazine before the film can be used for development in Tank PH-322. Do not wind the leader completely inside the magazine when the exposed film is rewound in the camera. Stop the rewinding process at the point where either the film counter or the film takeup knob stops rotating. At this point, the exposed film has been rewound into the magazine, and only the leader remains outside the magazine.
- (2) If the film leader is turned accidentally into the camera magazine, it can be retrieved by taking the magazine to a darkroom. Pull off either metal cap from the magazine and remove the spool of film. Be sure that the film does not spin loose from the spool. Hold the narrow leader end, slide it into the cloth-covered slot in the magazine, and replace the spool in the magazine. Be careful that neither the spool nor the magazine is turned end for end in any of these operations. After the metal cap is replaced, the magazine will again be lighttight, and the film will be ready to be loaded into Tank PH-322 (fig. 9) .
- (3) Remove the magazine chamber knob from Tank PH-322 (fig. 9) by lifting it vertically. Turn the collar so that the round-nosed index is at LOAD.



Figure 19. Reel of Tank PH-322, removed for loading.

- (4) To unlock the cover of the tank from the case, turn the locking knob clockwise until it springs up. The locking knob remains attached to the knurled collar. Lift the cover and reel assembly from the tank by the knurled collar.
 - (5) To prevent further rotation, turn the locking knob until it latches. Hold the cover assembly in the left hand and insert the 35-mm film magazine in the hub of the magazine chamber, with the extended hub of the magazine toward the right (figs. 19 and 20).
- c. *Threading Reel* (fig. 20).
- (1) Pull the leader end of the film forward to engage it with the knurled metal roller (figs. 19 and 20). Make sure that the end of the film is squarely against the shoulder (fig. 19) of the spiral hub and that the perforated edge of the leader is in contact with the small molded lug (fig. 20) of the bottom

flange. Hold the reel in the right hand push the knurled roller firmly toward the magazine with the thumb of the left hand. The film may not load properly if it is not fastened in the position shown (fig. 19).

- (2) Replace the cover assembly on the tank case.
- (3) To insert the magazine chamber knob (fig. 9) into the top of the magazine, push it down, and turn it slightly. The knob must be pushed downward until it is flush with the top edge of the magazine chamber. If it is not flush the film will be fogged while it is being loaded onto the reel.
- (4) Turn the magazine chamber knob clockwise until the film is taut.
- (5) Push the locking knob (fig. 9) downward and rotate it clockwise at the same time until it is tight. Gently and steadily turn the knurled collar (fig. 9) counterclockwise, as indicated by the arrow on the collar, to draw the film from the magazine into the spiral of the developing reel. Be careful to avoid jerky or erratic motion, which might cause the film to jump out of the proper track in the spiral. Approximately 7

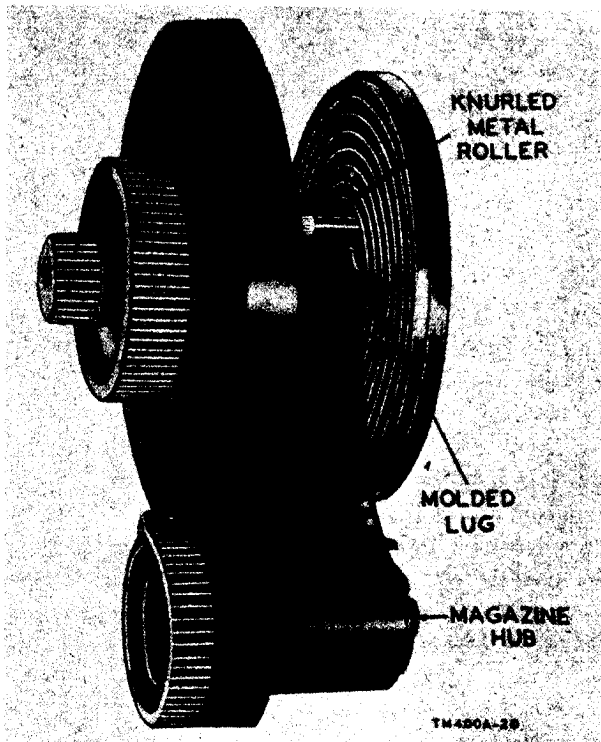

Figure 20. Starting positions for threading.

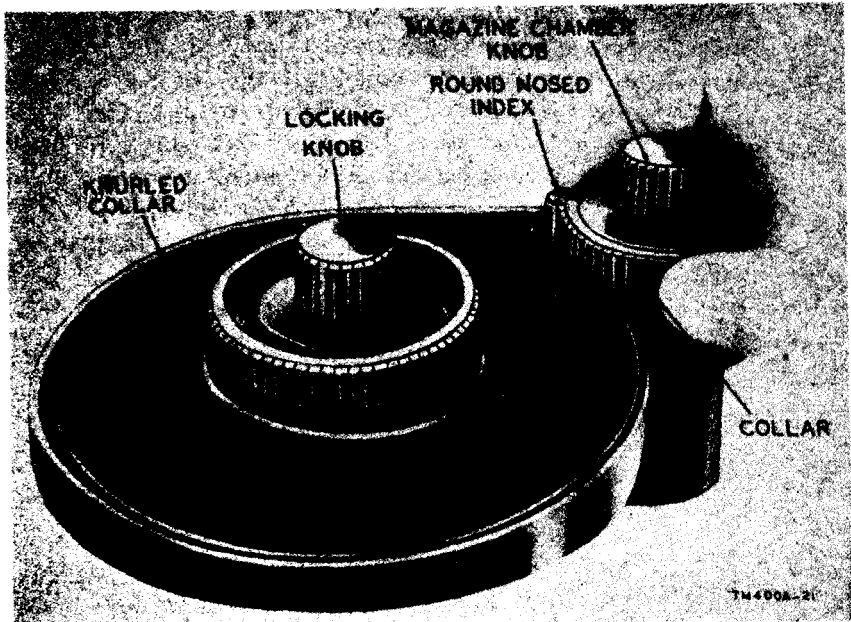

Figure 21. Cutting film after loading.

turns are required to load a length of film with 36 exposures. When the film has been completely loaded into the spiral, further rotation should not be forced.

- (6) To cut the film and make the developing chamber lighttight, turn the knurled collar and the round-nosed index (fig. 21) clockwise with a firm, rapid action to move the index pointer from LOAD to DEVELOP. Do not hold the magazine chamber knob.
- (7) Rotate the knurled collar (fig. 21) counterclockwise 1 full turn to draw the end of the film into the reel. Rotate the magazine chamber knob (fig. 9) clockwise 1 complete turn, and lift the empty magazine from the chamber.

d. Developing.

- (1) The temperature of the processing solutions should be kept between 65° and 75° F. (18° and 21° C.). A steady temperature of 68° F. (20° C.) is preferable. At higher temperatures, precautions are necessary to prevent excessive swelling and softening of the emulsion. Use Thermometer PH-28 to determine the temperature of the solution.
- (2) Set the hands of Timer PH-29 to 0 (60 on timer), and push the START-STOP lever to START; then pour the 16 ounces of developer solution from the graduate into the opening at the top of the magazine chamber. The magazine

chamber knob must be removed to disclose this opening. Replace the magazine chamber knob (fig. 9).

- (3) Agitate the film during development by rotating the knurled collar (fig. 9) in a counterclockwise direction only. To insure uniform development, agitate the film for 1 minute when it is first immersed and for 5 seconds at 2-minute intervals thereafter until development is complete.

Notes. At the end of the required developing time, push the **START-STOP** lever on the timer to **STOP**.

e. Rinsing. After development is complete, remove the magazine chamber knob and pour the developer out through the pouring lip on the end of the tank. Refill the tank immediately with clean water, agitate the film by rotating the knurled collar (fig. 9) for 30 seconds, and pour out the water.

f. Fixing.

- (1) Refill the tank with 16 ounces of fixer solution after developing and rinsing. Agitate for the first 30 seconds and for 5 seconds at 2-minute intervals thereafter until fixation is complete. Fix for 10 minutes if the solution is fresh.
- (2) Pour out the fixer; it may be saved and re-used four or five times if it is stored in a capped bottle.

g. Washing. Turn the knurled collar of the film magazine (fig. 21) to the **LOAD** position, and place the opening of the magazine chamber under a water faucet. Allow a slow, steady stream of water to flow into the tank for 1 hour. For faster washing or when water is scarce, remove the cover assembly and place the tank in a bucket or deep tray. Wash for 5 minutes each in six changes of water.

h. Drying (fig. 22). To dry the film, fasten the end, while it is still on the reel, to a film clip suspended from the ceiling or from a shelf. Depress the locking knob (fig. 21) to allow free rotation of the reel and pull the reel downward until the film is unwound. Release the film from the reel and place a second clip on the lower end for weight.

i. Wiping (fig. 23).

- (1) Wet the viscose sponge, squeeze out the excess water, and wipe the front and back of the film to remove water drops. Select a location which is free from dust. If the temperatures of the processing solutions and wash water exceed normal, the film emulsions may be excessively soft and swollen. In such cases the wiping must be omitted to avoid damage.
- (2) Hang the negatives up so that they may dry thoroughly before they are put in the negative carrier.
- (3) Wash out the tank, cover assembly, and magazine chamber knob; dry them thoroughly before re-using.

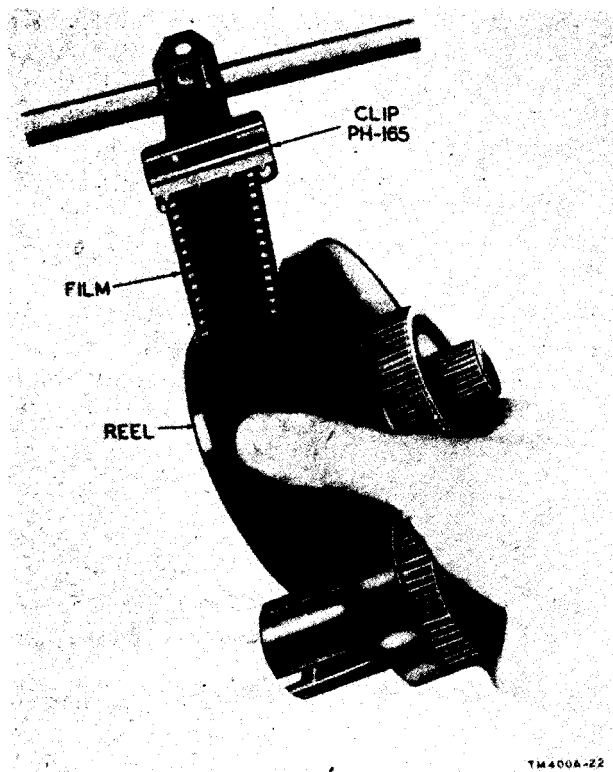

Figure 22. Removal of film for drying.

j. Cutting Film (fig. 21).

- (1) In cases where it is necessary to develop a few exposures at a time, the unexposed film can be saved for later use by cutting the film after the knurled collar (fig. 9) has been turned just enough to draw the exposed film length into the reel, as indicated below. Watch the arrow on the winding collar when counting the number of turns.

Full turns of knurled collar	Number of exposures plus film leader
2	5
3	10
4	16
5	22

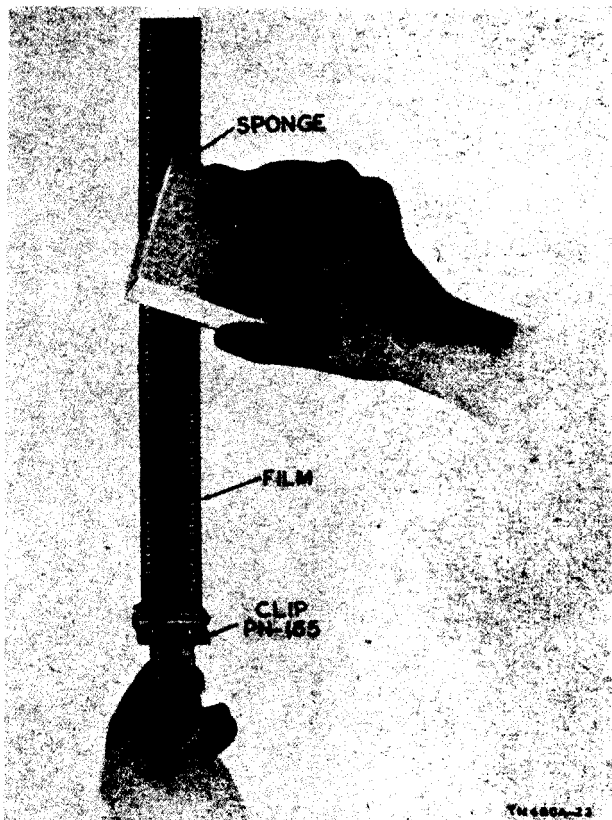

Figure 23. Wiping film.

- (2) After cutting the film, avoid drawing the end of the film into the magazine by twisting the magazine chamber knob counterclockwise just enough to allow the magazine to be lifted out.

Note. When developing a short length of film, make sure that the exposure counter was set properly when the camera was loaded, so that the actual number of exposures is correctly known. Before using the film left in the magazine, pull out about 4 inches from the magazine and cut off a strip, about one-third the film width and 3 to 3½ inches long, to form the narrow leader needed for loading the camera and the tank.

Section II. OPERATION UNDER UNUSUAL CONDITIONS

16. Unusual Conditions

Photographic Set ES-12 (1) is used normally in a shelter. However, when the unit has been stored outdoors or in shelters where extreme temperatures or climatic conditions are encountered, follow

the special procedures outlined in paragraphs 17 and 18 before the unit is placed in operation.

17. Operation in Arctic Climates

a. Transfer the unit from the cold to the warmer temperature, and allow it to remain at room temperature for approximately 6 hours before removal from the carrying case.

b. Do not open the carrying case before the unit has reached room temperature because water may condense on the unit and cause permanent damage. If possible, inclose the unit in water-repellent material (such as waterproof bags, shelter cloths, or other improvised coverings) while it is in the cold atmosphere, and then transfer it to the warmer room.

c. Before operating, clean the unit, and dry any water that has condensed on the moving parts. Use a lint-free cloth for this operation. If moisture has condensed on the surfaces of the projection lens or condenser lenses of the printer, carefully dry them with a soft, clean, dry, lint-free cloth or lens tissue.

18. Operation in Desert and Tropical Climates

a. If it is necessary to store the photographic set outdoors in excessively high temperatures, cover the carrying case with a shelter cloth or other improvised material to protect the contents from heat.

b. When the unit has been transferred indoors, carefully remove all dust and grit from the components with a camel's-hair brush. (If available, use an air syringe to remove dust and grit from the lens and condenser unit of the printer before using a camel's-hair brush.) After dusting the lenses with the brush, clean them with the lens tissue.

c. Photographic Set ES-12 (1) is moisture proofed and fungi-proofed during manufacture and can be operated without additional treatment.

CHAPTER 4

ORGANIZATIONAL MAINTENANCE

Section I. PREVENTIVE MAINTENANCE SERVICES

Note. The repair that can be performed at the organizational maintenance level is limited in scope by the tools and replaceable parts issued and by the existing tactical situation.

19. Definition and Importance of Preventive Maintenance

a. Definition. Preventive maintenance is work performed on equipment, usually when it is not in use, to keep it in good working condition so that breakdowns and needless interruptions in service will be kept to a minimum. It is not the same as trouble shooting or repair. The purpose of trouble shooting and repair is to *correct existing* defects. Preventive maintenance is designed to prevent the development of defects.

b. Importance. Since the failure or inefficient operation of even one component may cause the breakdown of the entire equipment the importance of preventive maintenance is obvious. Operators must maintain their equipment in such condition that it will work at top efficiency at all times.

20. Organizational Tools and Materials

The following tools and materials are required for organizational maintenance of Photographic Set ES-12 (1) :

Signal Corps stock No.	Name of material and description	Used to
6Z1372.....	Camel's-hair brush.....	Remove dust from the lenses, the condenser lens, inside the lamphouse, and all crevices.
6Z1989.....	Lint-free cloth (cheesecloth).....	Clean the camera case, the printer, and the other components.
8A819.....	Lens-cleaning fluid.....	Clean the lenses.
6R15410.....	Screw Driver TL-23, 3/16" bit.	Test the tightness of the screws.
6R5211A.....	Screw Driver TL-456/U, 3/16" bit.	Do.
6G236.5.....	Dry cleaning solvent (SD).....	Remove grease and dirt.
6Z973.....	Air syringe.....	Remove dust from the lenses and from the interior of the camera and the lamphouse.
8A2559.....	Lens tissue.....	Clean the lenses.

Caution: Emery cloth, sandpaper, crocus cloth, or similar abrasive materials must not be used when cleaning the plated surfaces of this equipment. Use only the cleaning fluid specified above. Do not use gasoline as a cleaning agent for this equipment.

21. Maintenance Procedures

The preventive maintenance check list (par. 22) for Photographic Set ES-12 (1) indicates what to check, when to check, how to check, and precautions to be taken before, during, and after checking. For preventive maintenance procedures for Camera PH-324-A, refer to TM 11-2361A; for Exposure Meter PH-260-A, refer to TM 11-2356.

22. Preventive Maintenance Check List

a. Photographic Equipment Carrying Case FM-22(1).

Item No.	What to check	When to check	How to check	Precautions
1	Safelight.....	D	Inspect lamp to determine if replacement is necessary.	Handle carefully to avoid breakage.
2	Timer PH-29.....	D	Inspect for damaged glass, dust, dirt, loose or missing screws, and winding keys.	Tighten screws snugly, but do not use force. Do not wind spring of timer too tightly.
3	Copy lights.....	D	Inspect lamp for replacement, and cable for damaged insulation.	Tighten lamps and keep cable clean.
4	Control unit (switches).....	W	Inspect switches for dirt, corrosion, loose contacts, and mechanical action.	Make sure switches are in off positions, or power cable is disconnected.
5	Power cables.....	W	Examine cable insulation for signs of deterioration or frayed insulation.	Keep cables clean.
6	Connector receptacles.....	W	Examine wire connections for possible looseness.	Tighten.

D—Daily; W—Weekly.

b. Flash Synchronizer.

Item No.	What to check	When to check	How to check	Precautions
1	Test lamp.....	D	Check operation of lamp. Replace if burned-out or broken.	Handle carefully.
2	Lamp ejector.....	D	Check operation for corrosion, dirt, and lack of tension.	Make sure a burned-out dash lamp is used for testing ejector.
3	Synchronizer cord.....	D	Check cord connectors for dirt, corrosion, and loose contacts.	Clean or replace if necessary.
4	Batteries.....	D	Check for clean contacts.....	Clean or replace.

D—Daily.

c. Photographic Projection Printer EN-11 (1).

Item No.	What to check	When to check	How to check	Precautions
1	Printer exterior (general)	D	Inspect for damaged baseboard, chipped finish on metal parts, dust, dirt, loose or missing screws, and loose knobs.	Tighten screws snugly, but do not use force. Replace any missing screws.
2	Power cable.....	W	Examine cable insulation for signs of deterioration. See that all connections are secure.	Keep cables clean.
3	Projection lens.....	D	Inspect for dirt, dust, mildew or fingerprints. Clean with an air syringe and a camel's-hair brush.	Avoid touching lens surface with fingers. Do not use lens tissue on lens surface unless foreign matter or fingerprints remain. Cover lens with lens cap.
4	Negative carrier.....	D	Inspect for dirt, dust, mildew or fingerprints. Dust with a lint-free cloth. Clean with a camel's-hair brush.	Remove all traces of lint.
5	Condenser lenses.....	D	Inspect for dirt, dust, mildew or fingerprints. If still dirty, dampen lens with lens cleaning fluid. Use a fresh piece of lens tissue and wipe dry.	Avoid touching lens surfaces with fingers.
6	Lamphouse.....	W	Inspect for dirt, dust, mildew or fingerprints. Remove all traces of dust with an air syringe and camel's-hair brush. Remove traces of dampness and mildew with a lint-free cloth.	Handle carefully to avoid damage to the printer lamp and lamp holder.

D—Daily, W—Weekly.

Section II. LUBRICATION AND WEATHERPROOFING

23. Lubrication

Except for the printer and camera, the components of Photographic Set ES-12(1) do not require lubrication. The support column and the friction wheel knob of the printer require lubrication every 500 operating hours. To lubricate the support column, wipe it with a clean, lint-free cloth dampened lightly with Aircraft Hydraulic Oil, Petroleum Base (OHA), which is usable in all working temperatures. To lubricate the friction wheel knob, wipe it with a clean dry cloth and coat it lightly with Aircraft and Instruments Grease (GL), which is usable in all working temperatures. In all lubrication, be sure that excess oil is wiped off. Make sure that no oil or grease is deposited on the projection lens or red filter.

Note. Refer to TM 11-2361A for detailed lubrication instructions for Camera PH-324-A.

24. Weatherproofing

a. General. Signal Corps equipment, when operated under severe climatic conditions such as prevail in tropical, arctic, and desert regions, requires special, treatment and maintenance. Fungus growth, insects, dust, corrosion, salt spray, excessive moisture, and extreme temperatures are harmful to most materials.

b. Tropical Maintenance. A special moistureproofing and fungi-proofing treatment has been devised which, if properly applied, provides a reasonable degree of protection. This treatment is explained fully in TB SIG 13, Moistureproofing and Fungiproofing Signal Corps Equipment, and TB SIG 72, Tropical Maintenance of Ground Signal Equipment.

c. Winter Maintenance. Special precautions necessary to prevent poor performance or total operational failure of equipment in extremely low temperature are explained fully in TB SIG 66, Winter Maintenance of Signal Equipment, and TB SIG 219, Operation of Signal Equipment at Low Temperature.

d. Desert Maintenance. Special precautions necessary to prevent equipment failure in areas subject to extremely high temperatures, low humidity, and excessive sand and dust are explained fully in TB SIG 75, Desert Maintenance of Ground Signal Equipment.

e. Lubrication. The effects of extreme cold and heat on materials and lubricants are explained in TB SIG 69, Lubrication of Ground Signal Equipment. Observe all precautions outlined in TB SIG 69, and pay strict attention to all lubrication orders when operating equipment under conditions of extreme cold or heat.

Section III. TROUBLESHOOTING AT ORGANIZATIONAL MAINTENANCE LEVEL

25. General

Familiarity with the equipment through operation will assist the operator to diagnose and make minor repairs. Any deviation from usual performances must be checked, its cause discovered, and repairs made. Major repairs of the equipment that cannot be performed by the operator must be referred to a higher repair authority. Certain corrective measures that can be performed at organizational maintenance level are discussed in paragraphs 21 and 22. Repair or replacement of all components is covered in paragraphs 39 through 42.

26. Visual Inspection

Generally, a visual inspection will indicate the cause of failure of a mechanical part. Electrical troubles usually require testing circuit components. However, examine all electrical parts for obvious faults, and repair them if possible. If the trouble cannot be located by visual inspection or by a check of equipment performance (par. 27), refer the component to a higher repair authority.

27. Troubleshooting (Using Equipment Performance Check list)

a. Purpose and Use.

- (1) *General.* The equipment performance check list (*b* below) will aid the operator in determining whether the equipment is functioning properly. The check list gives the item to be checked, the action or condition under which the item is checked, the normal indications of correct operation, and corrective measures that the operator can take. Items 1 through 16 are checked before starting, items 17 through 23 while operating, and items 24 and 25 when stopping.
- (2) *Action or condition.* For some items, the information given in the *Action or condition* column consists of the control setting at which the item is to be checked. For other items, it represents action that must be taken to check the normal indication listed.
- (3) *Normal indication.* The normal indications listed include the visible signs the operator will find when the items are checked.
- (4) *Corrective measures.* The corrective measures listed are those that the operator can make without turning the equipment in for repair. If the equipment is completely inoperative, or if the recommended corrective measures do not yield the desired results, turn the equipment in for repair by technical service personnel. For instructions on cleaning and replacing damaged parts of Camera PH-324-A, refer to TM 11-2361-A; for Exposure Meter PH-260-A, refer to TM 11-2356; and for Timer PH-29, refer to TM 11-405.

b. Equipment Performance Check List.

	Item No.	Item	Action or condition	Normal indications	Corrective measures
P R E P A R A T O R Y	1	Flash synchronizer.....	Mounts to bottom of camera. Position test lamp into lamp socket.	Firm, secure mounting..... Test lamp should flash or glow.	Tighten camera mounting screw (par. 12b). Check position of batteries. Check for short circuit. Change test lamp (par. 12b).
	2	Camera.....	Wind film in camera and release shutter (shutter release lever).	Trips shutter, flashes bulb, and exposes film.	Operate shutter several times. Replace flash batteries (par. 12b).
	3	Exposure meter.....	Needle pointer moves when photoelectric cell window is uncovered.	Moves from full scale to zero position.	Gradually uncover photoelectric cell window and observe movement of needle. Do not use meter if needle is jerky or irregular. Refer to higher authority for replacement or repair.
	4	Bracket (printer).....	Mounts camera.....	Positions camera for copy...	Loosen mounting screw, adjust, and tighten (fig. 15).
	5	Power cable.....	Connect to 110-volt ac or dc power source.	See item 6.....	See item 6.
	6	Accessory switch.....	Operate to on.....	Copy lamps light.....	Turn on lampholder turn-knobs. Check for defective lamps. See that connections are made properly. Check power source. Examine power cables for loose or broken connections (fig. 16).

P R E P A R A T O R Y

7 Processing tank (35-mm film).	Daylight loading-----	Film loads in tank for developing. Developed required time and removed from tank.	Check loading procedure (par. 15b). Check procedure (par. 15b).
8 Safelight switch-----	Operate to on-----	Safelight lamp lights-----	See that the 110-volt safelight lamp is being used. Use OA safelight (fig. 24). Check for defective lamp (fig. 24). See that connections are made properly. Check ac or dc power source. Examine power cable for loose or broken connections (fig. 24).
9 ENLARGER switch-----	Operate to on position-----	Printer lamp goes on-----	Remove lens cap. See that connections are made properly. Check power source. See that 115- to 125-volt printer lamp is being used (fig. 25). Replace printer lamp if defective. Examine cables for loose or broken connections (fig. 24). Check negative for evidence of foreign matter or scratches.
10 Condenser lens assembly--	Switch on light-----	Image should be free of spots and scratches.	Check condenser lens for foreign matter and clean if required (fig. 25). Check condenser lens for scratches or cracks (fig. 25). If lenses are damaged, refer to higher repair authority.

b. *Equipment Performance Check List.*—Continued

	Item No.	Item	Action or condition	Normal indications	Corrective measures
PREPARATORY	11	Lamphouse.....	Raised or lowered, as required, for correct enlargement size.	Image should be of desired size.	Loosen bracket locking knob, and raise or lower lamphouse as required (par. 14d (5)).
	12	Bellows.....	Raised or lowered, as required, for sharp focus.	Image should be sharp and clear.	Adjust with focusing knob (par. 14d (7)).
	13	Projection lens.....	Set diaphragm opening.....	Image should be sharp and clear.	Check focusing (par. 14d (7)).
	14	Red filter.....	Placed in position below projection lens.	Acts as safelight while positioning enlarging paper.	Check lens (par. 14d (7)). Check alinement of film stage with base (par. 44). Refer to higher repair authority.
	15	ENLARGER switch.....	Operate to the off position..	Printer lamp extinguished..	Check switch.
	16	Paper holder.....	Holds enlarging paper in position on base.	Supplies correct size and margin of print.	Check masking arms (fig. 18).

OPERATION	17	ENLARGER switch.....	Operate to the on position..	Printer lamp goes on..... Desired area is being framed on paper holder.	Check switch. Adjust paper holder for proper placement of image (fig. 18):
	18	Red filter.....	Move in front of projection lens.	Filters light from printing lamp.	Check red filter (fig. 17). Check printing lamp (fig. 25).
	19	Paper holder.....	Place enlarging paper in holder.	Paper is centered in holder..	Check masking arms of paper holder (fig. 18).
	20	ENLARGER switch.....	Operate to the off position..	Printing lamp goes out.....	Check switch (fig. 27). Check printing lamp (fig. 25).
	21	Red filter.....	Move away from projection lens.	Filter moves freely on its swivel.	Check the holder assembly and stud (fig. 25).
	22	Timer PH-29.....	Set for desired exposure and operate switch to START position.	Timer begins to tick.....	Check timer (fig. 8) (par. 22a).
	23	ENLARGER switch.....	Operate switch to the on position when starting timer, then operate to off position.	Printer lamp lights, exposure is made, and lamp goes out.	Check printing lamp (fig. 25). Check switch. Replace lens cap.
STOP	24	Enlarging paper.....	Remove from paper holder..	Process in normal way.	
	25	Power cable.....	Remove from ac or dc power source.	-----	

CHAPTER 5

THEORY

28. Flash Synchronizer (figs. 11 and 12)

The flash of the bulb coinciding with the opening of the camera shutter is called synchronization. Perfect synchronization occurs when the shutter operates at the same instant that the flash is at peak intensity. Synchronization is effected by the mechanism that operates the camera. The electrical circuit is closed at the exact instant the shutter reaches the completely open position.

Note. For information on the theory of Camera PH-324-A, refer to TM 11-2361A; for Exposure Meter PH-260A, refer to TM 11-2356.

29. Supplementary Lenses (fig. 4)

Supplementary lenses 1-plus or 2-plus make it possible for the camera to take portrait pictures, to copy, or to make photographs of small objects at short distances. When either one of these lenses is used in a filter holder over the lens of Camera PH-324-A, larger images in sharp fucus are secured. When using these supplementary lenses for copying, measure accurately the distance from the front of the supplementary lens to the subject. Also refer to Table I for copy work.

30. Lighting Equipment [Copy Lights] (fig. 16)

The lighting system of the equipment provides well-balanced illumination when using a 35-mm camera for closeups, microfilming, and copying. Some preliminary adjustments of the reflectors are necessary to give uniform light over the end of the field area. Two 150-watt enlarger lamps are mounted in the reflectors which have flexible arms. Both copy lamps are so spaced that light converges on the subject from both sides.

31. Photographic Projection Printer EN-11 (1)

The printer projects the enlarged image of a film negative onto the surface of sensitized photographic paper. The printer consists basically of a printer lamp, a condenser lens set, a negative carrier, a projection lens, and a baseboard. Light from the printer lamp is

reflected from the inside surfaces of the lamphouse and passes down through the condenser lenses, which direct the light in a narrow beam of parallel rays. The intensity of the beam is altered by the shaded areas of the negative as the beam passes through the negative. The projection lens throws the altered beam down on the baseboard in the form of a wide-angled cone. The image is brought into sharp focus by adjustment of a focusing knob which permits extension or retraction of the bellows to which the projection lens assembly is attached. The greater the distance between the negative and the baseboard, the larger the size of the projected image will be. A paper holder is placed on the baseboard directly under the projection lens to hold the sensitized paper on which an enlarged photographic print is to be made.

32. Board PH-317-A

Board PH-317-A is a board that holds copy material or sensitized enlarging paper. It lies in a horizontal position on the baseboard of the printer. The hinged printing frame of the board will hold an 8-inch by 10-inch (maximum) piece of sensitized printing paper. When Board PH-317-A is not available, the baseboard of the printer may be used to support the sensitized material,

33. Tank PH-322

The tank processes (in daylight) 35-mm black and white film (36 exposures) when the film is inclosed in daylight loading magazines. The exposed film is loaded in daylight on a reel supplied with the tank. The developer solution is poured into the opening at the top of the magazine chamber. Development is controlled entirely by time and temperature. The solution temperature is measured during development by removing the magazine chamber knob and inserting the thermometer.

CHAPTER 6

FIELD MAINTENANCE

Note. This chapter contains information on field maintenance. The amount of repair that can be performed by units having field maintenance responsibility is limited only by the tools and test equipment available, and by the skill of the repairmen.

Section I. INSPECTING, STRIPPING, AND CLEANING

Note. For information on inspecting, stripping, and cleaning Camera PH-324-A, refer to TM 11-2361A. For Exposure Meter PH-260-A, refer to TM 11-2356.

34. Inspecting

Inspecting by sight and touch often will determine the general condition of the equipment and the extent of repair required. The components included in Photographic Set ES-12 (1) are subject to very little wearing friction. Consequently, failure is infrequent except when due to breakage. Breakage is readily detectable in such components that are made of glass and plastics. Use the following information as a guide for making a visual and sensory inspection:

a. Photographic Equipment Carrying Case FM-22 (1).

(1) *Case, exterior and interior.*

(a) Examine the entire case for cracks, breaks, holes, and loose parts.

(b) Test the action of the switches on the control unit.

(c) Check all cables for damage, such as cuts or bad kinks.

(d) Check all connectors for damage.

(e) Open and close the case to see that it closes properly.

(2) *Safelight.*

(a) Examine the safelight for cracks, and check for burned-out lamp.

(b) Inspect the lamp holder for damage or defective contacts.

(c) Test the action of the SAFELIGHT switch on the control unit.

(3) *Timer PH-29.*

(a) Check for loose screws and nuts.

(b) Test the winding springs for overwinding.

(c) Check the action of the hour and minute hands.

(d) Look for rust, corrosion, or dents in the case.

(4) *Copy lights.*

- (a) Examine the power cable for broken wires and cracked or frayed insulation.
- (b) Inspect the lamp holders for damaged or defective contacts.
- (c) Check for burned-out lamps.

b. *Photographic Projection Printer EN-11 (1).*

(1) *Lamphouse.*

- (a) Check for loose screws, rust, corrosion or broken items.
- (b) Examine the projection lens for cracks, scratches, and chipping.
- (c) Remove the lamphouse cover, and examine the condenser lenses and heat-resisting glass for cracks or other damage.

(2) *Lamp.*

- (a) Inspect the lamp holder for damage or defective contacts.
- (b) Examine the power cable for broken wires and cracked or frayed insulation.
- (c) Check for faulty or broken connections in the connector.
- (o?) Check for burned-out lamp.
- (e) Test the action of the ENLARGER switch on the control unit.

c. *Flash Synchronizer.* Check the synchronizer cord for damage, such as cuts or bad kinks and broken connections in the connectors.

d. *Developing Tank and Trays.* Check all parts for evidence of cracks, breaks, or warping.

35. Stripping

Refer to TM 11-2361A for Camera PH-324-A, TM 11-405 for Timer PH-29, and to TM 11-2356 for Exposure Meter PH-260-A for instructions on stripping. Disassembly and reassembly instructions for the remainder of the photographic set are given in paragraphs 39 through 42.

36. Cleaning

a. Clean all mechanical parts with dry cleaning solvent, and lubricate the cleaned parts as required (par, 23).

b. Thoroughly rinse the processing tank, trays, stirring rods, glass graduate, and thermometer in clean water. Dry them with a clean, soft, lint-free cloth before repacking them and closing the case.

Caution: Never use alcohol or other solvents when cleaning lenses or filters; solvents may penetrate the lens barrel and separate the elements. Never immerse the lens in any cleaning agent or solvent.

c. Clean foreign matter from the lens with an air syringe or camel's-hair brush. Do not touch any lens surface with fingers or any other

object. Do not use lens tissue unless foreign matter or fingerprints remain on lens or filter surface.

Note. The safelight lamp should be disconnected from the power source before it is cleaned with lukewarm water.

d. Clean the shell of the eafelight lamp with glass cleaner or water and dry with a soft, lint-free cloth.

Section II. TROUBLESHOOTING AT FIELD MAINTENANCE LEVEL

Note. Refer to TM 11-2361A for troubleshooting information for Camera PH-824-A and to TM 11-2356 for Exposure Meter PH-260-A.

37. Preliminary Equipment Tests (fig. 24)

Before attempting to locate the trouble, check the electrical wiring for proper connections. In addition, check the wiring for short circuits that might be caused by poor connections or by cracked or frayed insulation. (Use Multimeter TS-352/U, SigC stock No. 3F4325-352, for wiring checks.)

38. Troubleshooting Chart

When it has been determined that trouble is not caused by poor wiring, use the procedure in the troubleshooting charts (*a*, *b*, and *c* below) to localize and correct the fault. Refer to paragraphs 40 through 42 for disassembly and reassembly procedures.

a. Photographic Equipment Carrying Case FM-22(1).

Symptom	Probable trouble	Correction
Safelight lamp does not light (fig. 2).	Defective power supply --	Check power supply and cable connection.
	Lamp burned out.....	Replace with recommended type of lamp.
	Defective switch.....	Replace switch (par. 42).
	Defective wiring.....	Repair or replace wiring (par. 42).
Winding keys of Timer PH-29 turn continuously when winding (fig. 9).	Winding springs loose or broken.	Repair or replace timer (note to section III).
Copy lamps do not light (fig. 2).	Defective power supply --	Check power supply and cable connection.
	Lamps burned out.....	Replace with recommended type of lamp.
	Defective ACC. RECEPTACLE switch or receptacle.	Replace switch or receptacle (par. 42).

a. Photographic Equipment Carrying Case EM-22(1).-Continued

Symptom	Probable trouble	Correction
Copy lamps do not light (fig. 2).-Continued	Defective wiring -----	Repair or replace wiring (par. 42).
	Defective lamp holders---	Replace lamp holders (par. 40a (1)).
Central unit switches turned on; no power (fig. 27).	Lamp switches not turned on.	Turn lamp switches on.
	Dirt, corrosion, or loose contacts.	Clean and tighten contacts.
	Defective switches -----	Replace switches (par. 42).
	Defective power cable or loose connections.	Examine cable insulation for signs of deterioration; see that all connections are secure.

6. Photograph Projection Printer EN-11 (1) .

Symptom	Portable trouble	Correction
Printing lamp does not light (fig. 25).	Voltage rating or printer lamp does not agree with voltage of power source.	use correct printing lamp.
	Printing lamp burned out.	Replace lamp.
	Faulty power cable -----	Replace cable (par. 41a).
	Faulty switch -----	Replace switch (par. 42).
	Faulty lamp holder -----	Replace lamp holder (par. 41a).
Portion of projected image cut off.	Negative improperly placed in carrier.	Correct negative position.
Spots on finished print.	Improper position of filter.	Adjust.
	Foreign matter on bottom condenser lens.	Clean condenser lens.
Scratch lines on finished print.	Foreign matter on negative.	Clean negative.
	Scratched negative -----	No remedy. Retake picture, if possible.
Enlargement not sharp-	Scratched or cracked condenser lens.	Replace lens (par. 41a (8)).
	Improper focusing -----	Refocus image and make a new print.
Improper operation of focusing mechanism (fig. 25).	Poor negative -----	Retake picture, if possible.
	Vibration of printer -----	Eliminate vibration.
	Foreign matter on projection lens.	Clean lens with camel's-hair brush.
	Lack of lubrication -----	Lubricate front of friction rod (par. 23).
	Excessive tension on friction rod springs.	Ease tension.

c. Flash Synchronizer.

Symptom	Probable trouble	Correction
Premature lamp flash (fig. 13).	Short circuit-----	Trace circuit. Place insulation between short.
Photo flash lamp will not flash.	Dead batteries----- Short circuit. Dead lamp- Battery upside down----	Replace (par. 12b (1)). Trace circuit. Reverse battery (par. 12b (1)).
	Paint on contact -----	Serape off paint.

Section III. REPAIRS

Note. Refer to TM 11-2301A for Camera PH-324-A, TM 11405 for Timer PH-29, and to TM 11-2356 for Exposure Meter PH-260-A for instructions on repairing.

39. Disassembly and Reassembly of Equipment at Field Maintenance Level

Except for the projection lens, repairs consist of replacing worn or damaged parts with new parts prior to reassembly. The least complicated parts of Photographic Equipment Carrying Case FM-22 (1), the enlarger, and lighting equipment can be repaired by the operator with ordinary tools. The more complex parts, including camera, lenses, shutter assembly and exposure meter, may be undertaken only by photographic equipment repairmen. Certain parts are permanently assembled in the equipment. The efficient replacement or repair of these permanently attached parts can be made only by skilled repairmen. Complete disassembly information for defects requiring extensive repairs or reconditioning is given in paragraphs 40 through 42.

Note. Tool Equipment TK-24/GF (Sig. C Stock No. 6R9S152-24) contains the tools necessary for photographic equipment repair. This tool kit is authorized for field and depot use.

40. Photographic Equipment Carrying Case FM-22 (1) (figs. 2 and 24)

a. Disassembly and Reassembly of Light Equipment (Copy Lights).

- (1) Unplug the cable connector from underneath the accessory (acc. receptacle) switch on the control board. Remove the light bulbs from the copy lights.
- (2) Loosen the cap from the shell by depressing on the split side; then twist and pull off the cap.
- (3) With the cap loosened, the socket and attached electric cord now may be partly pulled out of the flexible arm fitting.

- (4) Loosen the two terminal binding screws on the socket and pull out the cord.
 - (5) To reassemble the light equipment, reverse the disassembly procedure.
- b. *Removal and Replacement of Safelight Lamp.*
- (1) To remove the safelight, rotate the lamp in a counterclockwise direction. Be sure to hold the lamp during this procedure.
 - (2) Grasp the top end of the safelight and unscrew the filter shell to remove it.
 - (8) Unscrew and lift out the 7-watt lamp.
 - (4) To replace the safelight lamp, reverse the disassembly procedure ((1) through (3) above).

41. Photographic Projection Printer EN-11 (1)
(figs. 25 and 26)

a. *Disassembly and Reassembly of Lamphouse (fig. 26)*

- (1) Remove the negative carrier (13) by sliding it out from the lamphouse (1).
- (2) Unscrew the two cover machine screws (5) and remove the lamphouse cover (39) and baffle plate (30).
- (3) Remove the printer lamp (36) by exerting a slight pressure inward and turning it counterclockwise.

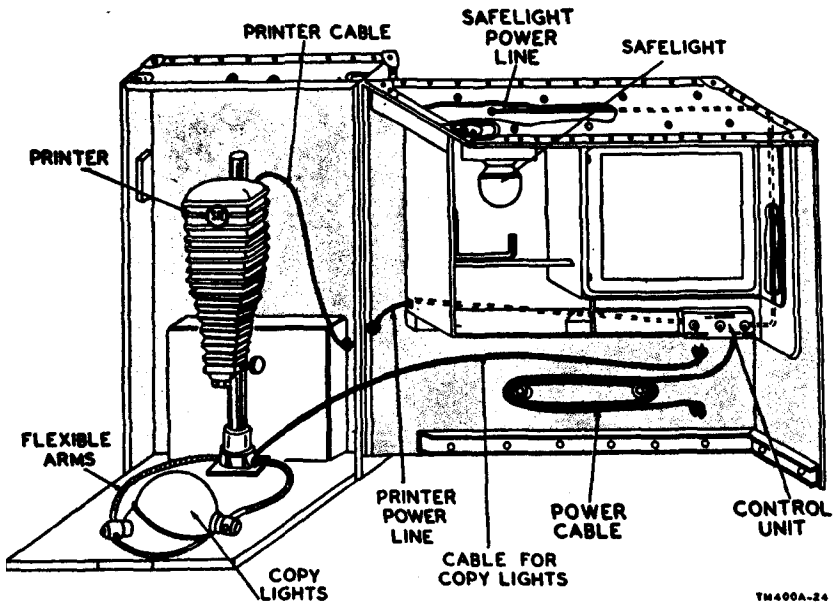

Figure 24. Part of Photographic Equipment Carrying Case FM-22 (1), showing cables for connecting components.

- (4) Unscrew the four machine screws (38) that hold the retaining baffle plate (37) and pull out the two condenser lenses (35) and heat-resisting glass (34).
- (5) Unscrew the two machine screws (31) and washers (32) that secure the lampholder (33) in the lamphouse (1).
- (6) Pull out the lampholder (33) and disconnect the cable leads of the power cable (4) from the two terminals. Remove the insulator (3) when disconnecting the power cable (4).
- (7) Repair or replace the lampholder (33) and/or the power cable (4), if necessary, and connect the leads to the terminals.
- (8) Examine the condenser lenses (35) and heat-resisting glass (34) ; clean and replace them in the proper grooves of the

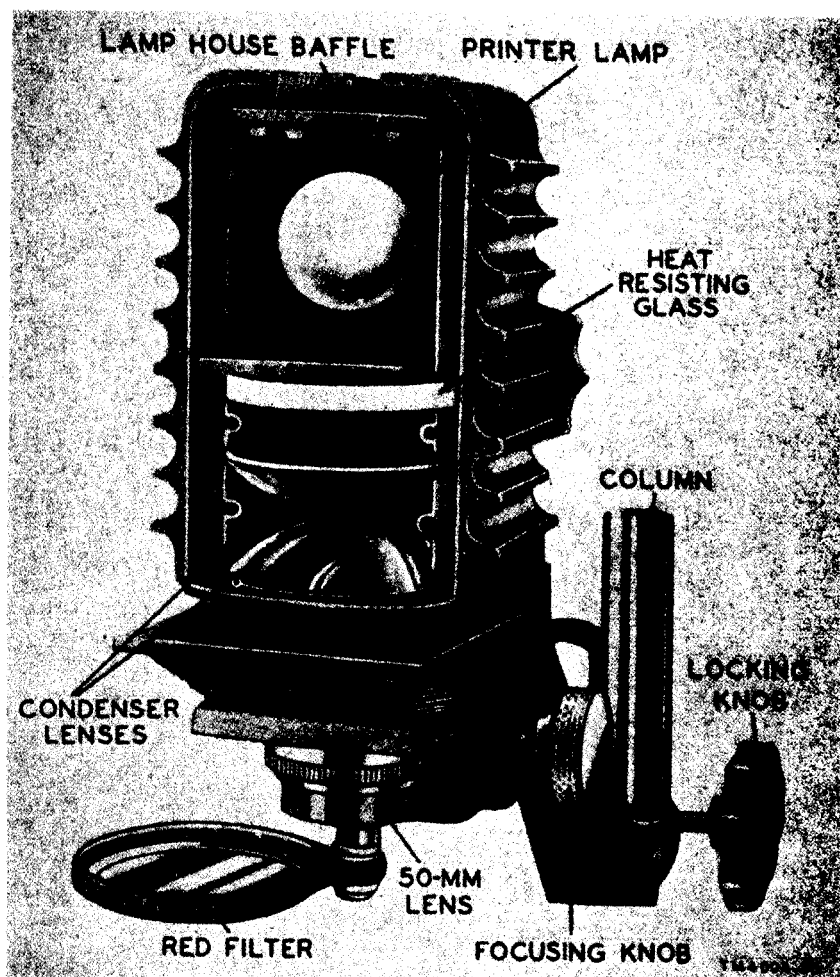

Figure 25. Lamphouse assembly, front plate removed.

lamphouse (1). Be sure that the lenses are seated in the grooves. Do not touch the surfaces with the fingers while replacing the lenses. (Replace lens and heat-resisting glass if necessary).

- (9) To reassemble the lamphouse, reverse the disassembly instructions (1) through (8) above).

b. Removal and Replacement of Bellows.

- (1) Turn the focusing knob (9) until the bellows (18) is collapsed.
- (2) Remove the two machine screws (15) that hold the upper bellows bracket (14) to the lamphouse (1).
- (3) Remove the four wood screws (16) that hold the bellows (18) to the upper bellows bracket (14).
- (4) Remove the machine screw (7) that holds the focusing guide rod (6), and pull off the upper bellows bracket (14).
- (5) Remove the two wood screws (17) that hold the bottom of the bellows to the focusing bracket (19) and remove the bellows (18) .
- (6) To replace the bellows reverse the disassembly procedure ((1) through (5) above).

c. Removal and Replacement of Lens Mount.

- (1) To remove the projection lens (22), unscrew it from the focusing bracket (19).
- (2) Remove the three machine screws (21) that secure the lens flange (20) to the focusing bracket (19) .
- (3) To replace the projection lens (22) and the lens flange (20), reverse the disassembly procedure ((1) and (2) above).

d. Removal and Replacement of Red Filters.

- (1) Remove the roundherd machine screw (29), washers (24 and 28) and compression spring (25) that hold the red filter holder assembly (26) and spacer stud (27) to the focusing bracket (19).
- (2) Remove the retaining spring from the holder and remove the filter.
- (3) To replace a new red acetate filter in the red filter holder assembly (26), reverse the disassembly procedure ((1) and (2) above).

e. Removal and Replacement of Focusing Mechanism.

- (1) To remove the two spring holders (12) from the focusing knob (9) assembly, unscrew the four machine screws (11).
- (2) Withdraw the focusing knob (9) and remove the guide roller (8) by loosening the set screw (10),
- (3) To replace the focusing mechanism reverse the disassembly procedure ((1) and (2) above). When replacing the focus-

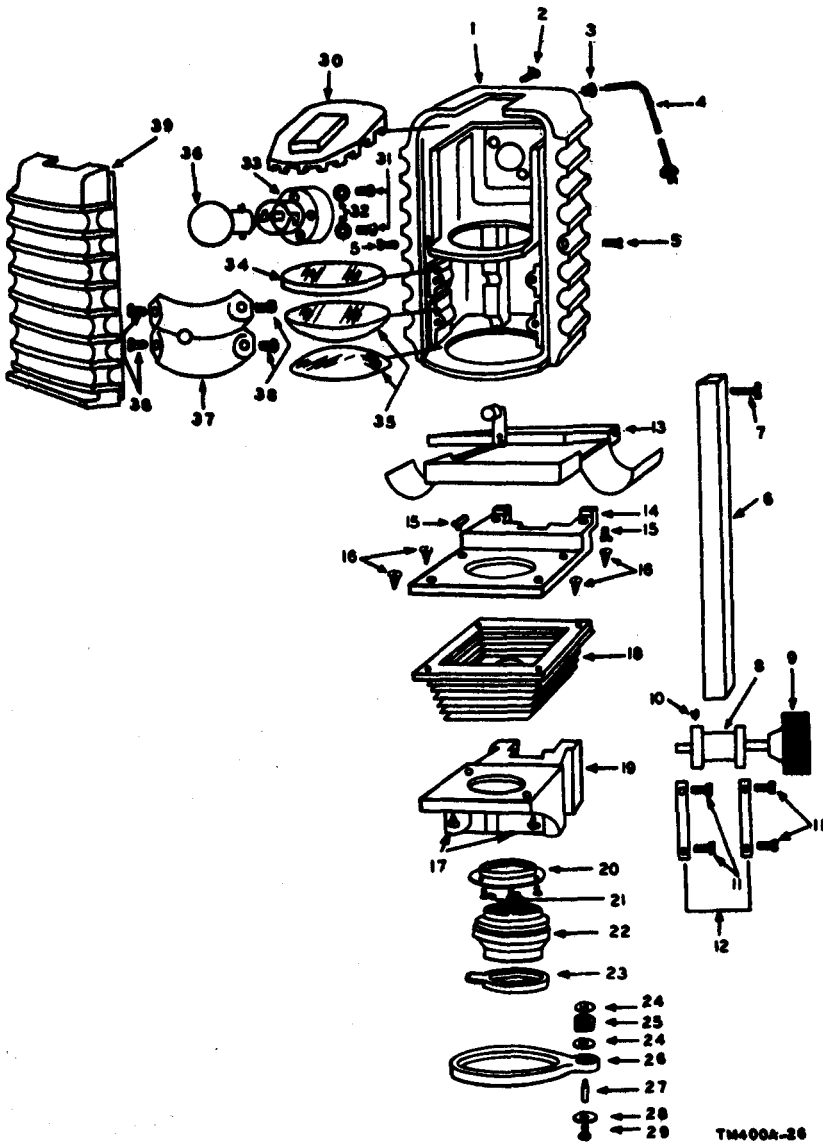

Figure 26. Photographic Projection Printer EN-11 (1), exploded view.

ing mechanism, be sure the guide roller (8) is secured in its proper place.

42. Disassembly and Reassembly of Power Cable in Photographic Equipment Carrying Case FM-22(1)

a. Unwind the power cable assembly (fig. 24) from the retaining pegs in the case.

b. Remove the four screws from the switch plate and pull the plate away from the switch control unit box (fig. 27).

c. Loosen the cable clamp on the power cable assembly within the switch control unit box. Remove the friction tape from the one wire lead (5) of the power cable assembly and disconnect the other lead from terminal (10) of the receptacle. Pull the power cable assembly from the hole in the bottom of the switch control unit box.

d. To replace the cable assembly, switches, or receptacle, disconnect the wires of the cable from the items to be replaced. Label all wire leads as numbered, and connect as illustrated in figure 27.

e. To reassemble the power cable, reverse the disassembly procedure.

Note. Switches are removed for replacement by unscrewing the knurled retaining rings.

43. Refinishing Procedures

Check all wooden and metal surfaces for appearance and condition of finish. The finish should not show decided wear and should not be chipped or otherwise damaged. Where the finish has been removed completely or has worn thin, retouch the affected surfaces. First,

1 Lamphouse (A 11)	21 Machine screw (H 5)
2 Machine screw (H 9)	22 Projection lens (I 2)
3 Insulator (E 1)	23 Lens cap (O 2)
4 Power cable (W 1)	24 Flat washers (H 22)
5 Machine screw (H 10)	25 Compression spring (O 13)
6 Focusing guide rod (O 11)	26 Red filter holder assembly (A 10)
7 Machine screw (H 15)	27 Spacer stud (H 19)
8 Guide roller (O 12)	28 Flat washer (H 20)
9 Focusing knob (O 7)	29 Machine screw (H 11)
10 Set screw (H 6)	30 Baffle plate (A 12)
11 Machine screw (H 7)	31 Machine screw (H 12)
12 Spring holders (O 15)	32 Flat washer (H 21)
13 Negative carrier (O 3)	33 Lamp holder (J 1)
14 Bellows bracket (A 4)	34 Heat-resisting glass (MS 1)
15 Machine screw (H 16)	35 Condenser lens (I 1)
16 Wood screw (H 17)	36 Printer lamp (E 2)
17 Wood screw (H 18)	37 Retaining baffle plate (A 13)
18 Bellows (H 1)	38 Machine screw (H 8)
19 Focusing bracket (A 5)	39 Lamphouse cover (A 5)
20 Lens flange (A 8)	

Figure 26—Continued

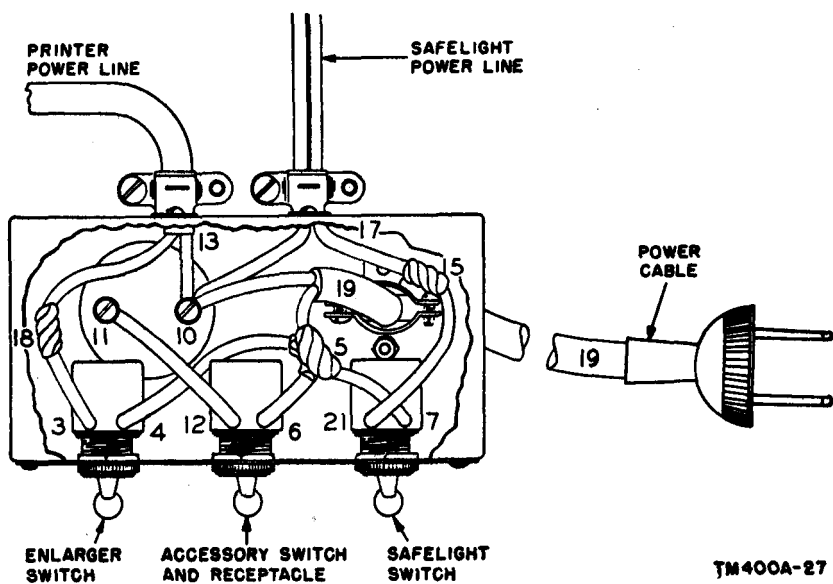

Figure 27. Control unit, wiring diagram.

clean and sand; then, apply one coat of clear lacquer to parts that have a bright finish and one coat of matching enamel on painted surfaces. Do not apply lacquer to springs, gears, or other surfaces that will affect the functioning of the printer, timer, or safelight.

Section IV. FINAL TESTING

Note. Refer to TM 11-2261A for Camera PH-324-A and to TM 11-2356 for Exposure Meter PH-260-A for instructions on adjustments.

44. Adjustments and Checks of Printer

After the printer has been reassembled, make the following preliminary adjustments and checks:

- a. Adjust the freedom of motion of the focusing mechanism by turning the screws (11, fig. 26) to increase or decrease tension of the springs in the spring rollers (12) against the guide roller (8).
- b. Place the paper holder on the printer baseboard.
- c. Place a sheet of white paper in the paper holder.
- d. Place a sharp negative in the negative carrier.
- e. Open the projection lens diaphragm to $f/4.5$ (widest opening).
- f. Operate the switch to illuminate the printer lamp.
- g. If the image on the white sheet of paper appears sharp in the four corners, as well as the middle, the printer is in horizontal adjustment.

h. If the image does not appear sharp in the four corners, as well as the middle check the alinement of the holder, and cheek the reassembly of the focus slide (par. 41*e*), the film-stage frame, and the condenser lens assembly (par. 41*a*). Realine where necessary.

45. Final Testing

Make final tests with the equipment operating under normal operating conditions. Use a negative that is known to be in good condition. After an exposure has been made, examine the developed print for evenness of exposure, proper definition, and absence of specks caused by dirt or dust. For this test, use a minimum of three prints.

CHAPTER 7

SHIPMENT AND LIMITED STORAGE AND DEMOLITION TO PREVENT ENEMY USE

46. Repacking for Shipment or limited Storage (figs. 2 and 3)

a. *Domestic shipment.* To pack for shipment or limited storage proceed as follows:

- (1) Return all equipment and supplies to the proper storage spaces. Tighten all holding screws and doors and fasten the holding straps.
- (2) To close the door of the right-hand section, swing the timer forward and out of the way. After the door has been fastened, press the timer back.
- (3) Lower the printer bracket as far as it will go on the column. Remove the negative carrier from the enlarger and store it in the compartment of the case.
- (4) Wind the extension power cable snugly around the pegs and place the copy light cable above it on the pegs.
- (5) Bend the copy lights (fig. 28) down flat against the base-board with no part extending beyond its edges. Close the case and secure the fastenings.

Caution: If the case does not close readily, do not force it. Check for interference and rearrange properly.

- (6) Slip on the canvas cover and snap the fasteners on the cover to the case.
- (7) Place the carrying strap under the case and up through the handles. Fold in the bottom edge of the cover flaps.
- (8) Place the case within a corrugated fiberboard carton and seal the carton with gummed tape.
- (9) Place the package within a nailed wooden case and bind the case with metal straps.

b. *Export Shipment.* To pack for export shipment proceed as follows:

- (1) Follow instructions in a (1) through (9) above.
- (2) Then place the packaged equipment in a second corrugated carton which is lined with a moisture-vaporproof liner.

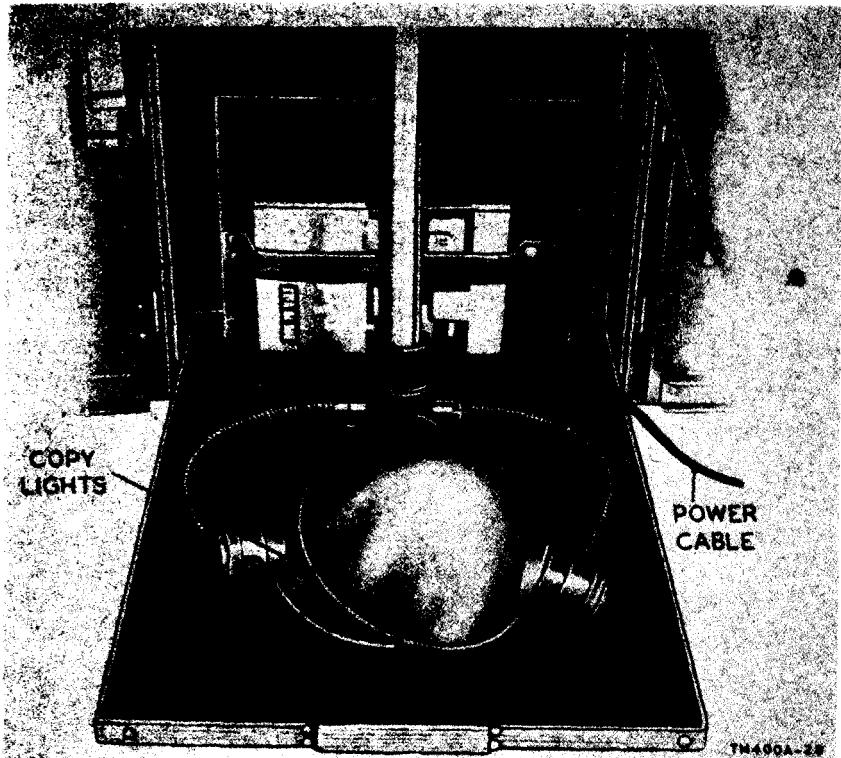

Figure 28. Copy lights in position for closing Photographic Set ES-12 (1).

(3) Place this package in the nailed wooden shipping container which is also lined with a moisture-vaporproof liner.

(4) Nail on the lid and bind the container with metal straps.

47. Destruction of Components

Follow the demolition procedures outlined in paragraph 48 to prevent the enemy from using or salvaging the equipment. Demolition of the equipment will be accomplished only upon order of the commander.

48. Methods of Destruction

a. Smash. Smash the camera and component parts, the printer, board, graduate, rod, tank, thermometer, trays, clips, ruler, lamps, timer, batteries, safelight, copy light, flash synchronizer and camera mounting clamp and exposure meter; use sledges, axes, handaxes, pickaxes, hammers, crowbars, or other heavy tools.

b. Cut. Cut the cable release and cables; use axes, handaxes, or machetes.

c. Burn. Burn the case cover and strap, camera case, film, board, chemicals, sponge, blotters, enlarging paper, lens tissue books, and cloth; use gasoline, kerosene oil, flamethrowers, or incendiary grenades.

d. Explosives. If explosives are necessary, use firearm, grenades or TNT.

e. Disposal. Bury or scatter the destroyed parts in slit trenches foxholes, *other* holes, or throw into streams.

f. Destroy. Destroy everything.

[AG 413.58 (8 Dec 54)]

INDEX

	<i>Paragraph</i>	<i>Page</i>
Accessories, developing-----	<i>4n</i>	8
Arctic climates, operation-----	17	51
Attaching lens hood and filter-----	<i>12a</i>	24
Bellows-----	<i>4i</i> (4)	8
Board PH-317-A-----	<i>4j</i> , 32	8,63
Bracket, printer-----	<i>4i</i> (5)	8
Cable release-----	<i>4g</i>	8
Camera PH-324-A-----	<i>4b</i>	8
Carrier, negative-----	<i>4i</i> (3)	8
Case, Photographic Equipment Carrying, FM-22(1),description-----	<i>4a</i>	8
Chart, trouble location-----	38	66
Checking-----	<i>8c</i>	19
Checklist:		
Equipment performance-----	27	57
Preventive maintenance-----	22	64
Chemicals, mixing-----	<i>15a</i>	44
Clamp, camera mounting-----	<i>4d</i>	8
Cleaning-----	36	65
Climates, operation:		
Arctic-----	17	51
Desert-----	18	51
Tropical-----	18	51
Clip PH-165-----	<i>4n</i> (9)	8
Common names-----	6	16
Components:		
Destruction-----	47	77
Photographic Set ES-12(1), description-----	4	8
Table-----	<i>3b</i>	3
Connections, electrical-----	<i>9d</i>	20
Condenser lenses-----	<i>4i</i> (2)	8
Controls:		
Photographic Equipment Carrying Case-----	10	24
Cover and carrying strap-----	<i>4a</i> (1)	8
Cutting film-----	<i>15j</i>	44
Definition, preventive maintenance-----	20	63
Demolition of materiel:		
Methods of destruction-----	48	77
Description of components, Photographic Set ES-12 (1)---	4	8
Desert climates operation-----	18	51
Destruction of components-----	47	77
Determining correct exposure-----	<i>13f</i>	32

	<i>Paragraph</i>	<i>Page</i>
Developing:		
Film-----	15d	44
Prints-----	14g	39
Solutions, preparing-----	15	44
Disassembly and reassembly:		
Photographic Equipment Carrying Case FM-22 (1), light equipment and safelight-----	40, 42	68, 73
Photographic Projection Printer EX-11 (1)-----	41	69
Drying, film-----	15h	44
Electrical requirements-----	9b (3)	20
Enlarging:		
Board PH-317-A-----	14c	39
Controls-----	10c	22
Developing prints-----	14g	39
Disassembly and reassembly-----	40	68
Focusing-----	14d	39
Inspecting-----	34b	64
Loading negative carrier-----	14b	39
Lubrication-----	23	56
Operation of enlarger-----	14f	39
Test prints-----	14e	39
Theory of operation-----	31	62
Equipment:		
Performance check list-----	27b	57
Test, preliminary-----	37	66
Exposure Meter PH-260-A-----	4h	8
Film-----	4f	8
Film choice-----	13b	32
Filter-----	3b	3
Final adjustments and testing-----	44	74
Final testing-----	45	75
Fixing-----	15f	44
Flash photography-----	12	24
Focusing adjustments-----	13d	32
Focusing camera-----	12c	24
Focusing enlarger-----	14d	39
Forms and records-----	2	3
General and flash photography-----	12	24
General description-----	3a	3
Graduate PH-11-----	4n (4)	8
Illumination-----	13e	32
Inspecting-----	34	64
Photographic Equipment Carrying Case FM-22(1)---		
Instruction, preliminary operating-----	11	24
Lamps-----	4m	8
Lens attachments-----	4e	8
Locating equipment-----	9	20
Location chart, trouble-----	38	66
Lubrication-----	23	56

	Paragraph	Page
Maintenance:		
Desert-----	<i>24d</i>	56
Preventive:		
Check list-----	22	54
Definition-----	<i>19a</i>	52
Importance-----	<i>19b</i>	52
Lubrication-----	<i>24e</i>	56
Tropical-----	<i>24b</i>	56
Winter-----	<i>24c</i>	56
Methods of destruction-----	48	77
Micro film-----	<i>13g</i>	32
Mixing chemicals-----	<i>15a</i>	44
Negative carrier-----	<i>5i</i> (3)	15
Nomenclature assignments-----	6	16
Operating instructions:		
Enlarger-----	<i>14f</i>	39
Instructions, preliminary-----	11	24
Operation under unusual conditions:		
Arctic climate-----	17	51
Desert and tropical climates-----	18	51
Unusual conditions-----	16	50
Theory:		
Board PH-317-A-----	32	63
Lighting equipment-----	30	62
Photographic Projection Printer EN-11(1)-----	31	62
Supplementary lenses-----	29	62
Synchronizer, flash-----	28	62
Tank PH-322-----	<i>15b</i> , 33	44, 63
Organizational, tools and materials-----	20	53
Packaging and packing data-----	7	16
Packing data packaging and-----	7	16
Performance check list, equipment-----	27	57
Photoflash exposure table-----	<i>12d</i>	24
Photographic Set ES-12(1):		
Description of components-----	4	8
General-----	<i>3a</i>	3
Repacking-----	46	76
Preliminary:		
Equipment tests-----	37	66
Operating instructions-----	11	24
Preventive maintenance:		
Check list-----	22	54
Definition-----	<i>19a</i>	52
Importance-----	<i>19b</i>	52
Photographic Projection Printer EN-11 (1)-----	<i>4i</i> , 31	8, 62
Print test-----	<i>14e</i>	39
Procedures, refinishing-----	43	73
Processing-----	15	44
Purpose and use, troubleshooting-----	27	57
Scope-----	1	3
Setting up for copying-----	<i>13c</i>	32
Shipment and limited storage-----	46	76

	Paragraph	Page
Solutions, preparing-----	15	44
Space requirements-----	<i>9b</i> (2)	20
Stripping-----	35	65
Supplementary lenses-----	29	62
Table:		
Componets-----	<i>3b</i>	3
Continuous tone and line copying-----	<i>13f</i> (3)	32
Controls-----	10	22
Field size for copying-----	<i>13d</i> (3)	32
Organizational tools and materials-----	20	53
Photoflash exposure-----	<i>12d</i>	24
Technical characteristics-----	5	15
Tank PH-322-----	<i>4k, 15, 33</i>	8, 44, 63
Controls-----	<i>10d</i>	22
Technical characteristics-----	5	15
Testing, final-----	45	75
Tests, preliminary equipment-----	37	66
Theory of operation:		
Board PH-317A-----	32	63
Lighting equipment-----	30	62
Photographic Projection Printer EN-11 (1)-----	31	62
Supplementary lenses-----	29	62
Synchronizer, flash-----	28	62
Tank PH-322-----	15, 33	44, 63
Thermometer PH-28-----	<i>4n</i> (7)	8
Timer PH-29-----	<i>4a</i> (2)	8
Control-----	<i>10b</i>	22
Tropical climates, operation-----	18	51
Trouble location chart-----	38	66
Uncrating-----	<i>8a</i>	19
Unpacking-----	<i>8b</i>	19
Unusual conditions-----	16	50
Visual inspection-----	26	57
Washing-----		44
Water requirements-----	<i>9b</i> (4)	20
Weatherproofing-----	24	56

BY ORDER OF THE SECRETARY OF THE ARMY:

M. B. RIDGWAY,
General, United States Army,
Chief of Staff.

OFFICIAL:

JOHN A. KLEIN,
Major *General, United States Army,*
The Adjutant Geneva.?

DISTRIBUTION :

Active Army:

Tec *svc*, DA (1)
Tec *svc* Bd (1)
AFF (5)
AFF Bd (incl ea Test See) (1)
Army AA Cored (2)
OS Maj Cored (5)
OS Base Cored (5)
Log Comd (5)
M D W (1)
Armies (5)
Corps (2)
Tng Div (2)
Ft & Cp (2)
Gen & Br *Svc* Sch (5)
SigC Sch (25)
Gen Depots (2)
SigC Sec. Gen Depots (10)

SigC Depots (20)

POE (2)

OS Sup Agencies (2)

SigC Fld Maint Shops (3)

SigC Lab (5)

Mil Dist (1)

Units organized under following

TOE's:

11-127, Sig Rep Co (2)

11-128A, Sig Depot Co (2)

11-500A (AA thru AE), Sig
Admin Teams (2)

11-587A, Sig Base Maint Co (2)

11-592A, Hq & Hq Co, Sig Base
Depot (2)

11-597A, Sig Base Depot Co (2)

NG: Same as Active Army except allowance is one copy for each unit.

USAR: None.

Unless otherwise noted, distribution applies to Con US and overseas,

For explanation of abbreviations used, see SR 320-50-1.

TM 11-400A—PHOTOGRAPHIC SET ES-12 (1)—1955

PIN : 015853-000